

MUTOH

XPJ-1641SR-P II

Operation Manual

Operations and Maintenance Methods

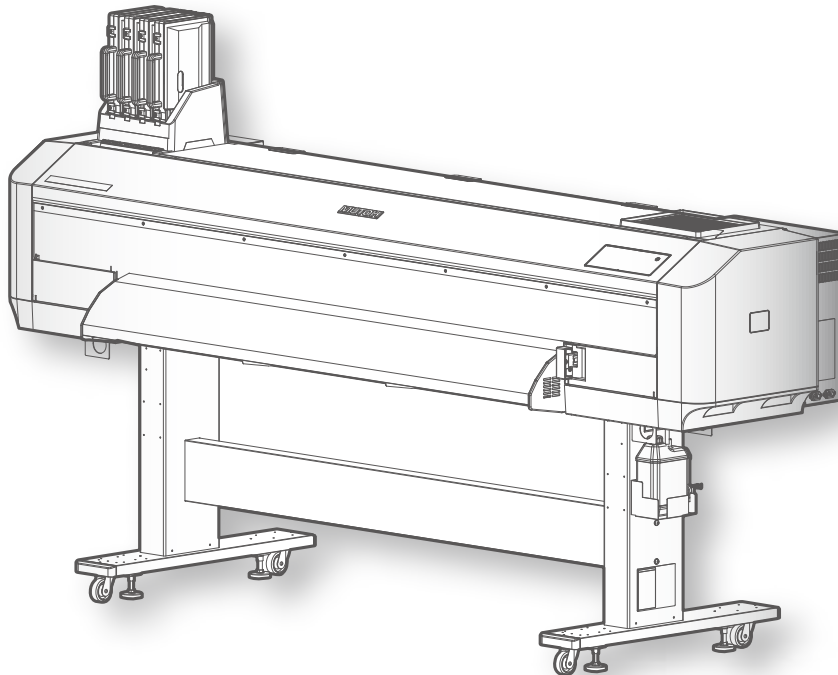

Important Notice

For Users in Europe

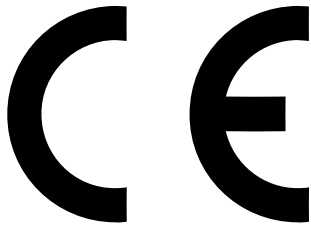

The CE marking is a mandatory European marking for certain product groups to indicate conformity with the essential health and safety requirements set out in European Directives.

By affixing the CE marking, the manufacturer, his authorized representative, or the person placing the product on the market or putting it into service ensures that the item meets all the essential requirements of all applicable EU directives and that the applicable conformity assessment procedures have been applied.

For Users in the United States

This equipment has been tested and found to comply with the limits for a Class A digital device, pursuant to Part 15 of the FCC Rules. These limits are designed to provide reasonable protection against harmful interference when the equipment is operated in a commercial environment. This equipment generates, uses, and can radiate radio frequency energy and, if not installed and used in accordance with the instruction manual, may cause harmful interference to radio communications.

Operation of this equipment in a residential area is likely to cause harmful interference in which case the user will be required to correct the interference at his own expense.

CAUTION

Use of controls or adjustments or performance of procedures other than those specified herein may result in radiation exposure.

Microsoft® and Windows® are either registered trademarks or trademarks of Microsoft Corporation in the United States and/or other countries.

VerteLith™ is trademark of MUTOH INDUSTRIES LTD.

Company names and product names that appear in this Guide are registered trademarks or trademarks of the respective companies.

- Unauthorized copying or duplication of the whole or part of the contents of this Guide is prohibited.
- Every care has been taken in writing the contents of this Guide, but please contact MUTOH or the dealer you purchased the product from if you find any unclear, erroneous or otherwise unsatisfactory content in the Guide.
- Please be aware that MUTOH will not be liable in any way for failures or accidents that result from handling or operating the printer according to any procedures other than those set forth in this Guide.
- To return to original place after clicking link in the table of contents or reference, tap **Alt** + **←** keys.

Table of Contents

For Safe Use

9

Safety Precautions	10
Symbols	10
Usage Precautions	11
When something wrong occurs	11
Product handling	12
Power cords	13
Printer installation and moving	15
About Maintenance	16
Ink and waste fluid	17
Warning labels	18
Instruction Labels	21

Before Use

22

Printer main components / Functions	23
Front view	23
Rear view	25
Printer control panel	27
How to use the printer control panel	27
Name of parts / Functions	27
Direct keys	28
Computer requirements	29
System configurations	30
Launching/ Opening/ Exiting MSM	31
Launching MSM	31
Opening MSM	31
Displaying remote panel	31
Exiting MSM	31
Printing area	32
Supported media	33
Media size	33

Media handling cautions	34
Precaution on storing media after use	34
Precautions	35
Please use this printer regularly	35
Please handle ink bag carefully	35
Please conduct maintenance regularly	35
Some parts need to be replaced periodically	36

Basic Operations

37

Printing workflow	38
Power Operation	39
Turn on the printer	39
Sleep Mode	40
Start the sleep mode	40
Wake up from sleep mode	41
Turn off the printer	42
Load the media into the printer	43
Loading the media into the printer	43
Step1. Attach the flanges to the media	43
Step2. Enable torque on media holders	45
Step3. Placing the media onto the media holder	46
Step4. Load media into the printer	50
Step5. After loading the media	53
Nozzle check and head cleaning	56
Run a nozzle check	56
Perform a head cleaning	58
Calibrating your printer	59
Settings depending on media	60
Print head height	61
Change print head height	62
Replace the cleaning wiper depending on the print head height	63
Change the way to use the edge holder depending on the media being used	64
Change pressure that comes onto entire media	65
Change pressure of pressure rollers individually	66
To set the slide lock lever to “Normal”	67
To set the slide lock lever to “Low”	68

To set the slide lock lever to “Cancel”	69
Start printing	71
Print an image.....	71
Pause / Resume / Cancel a print job.....	75
Operating from the printer control panel	76
Feeding media	76
Pause / Resume printing.....	77
Cancel printing	78
Start printing during warm-up	79
Cutting Media	80
Menus you can access while printing.....	81
Checking ink level and replacing ink bag.	83
Checking ink level	83
When an ink bag is nearing replacement	84
Replacing ink bag.....	85
Removing the ink bag case.....	85
Loading a new ink bag.....	86

Various settings

89

Panel setup menu	90
How to operate the menu.....	90
Menu1: Media Type	92
Adjust Print	94
Adjust Print: When [Auto] is selected	96
Adjust Print: When [Standard] / [Custom] is selected.....	97
Media feed adjustment.....	100
Run an automatic media feed adjustment	102
Run a media feed adjustment manually	103
Menu2: Maintenance	107
Automatic nozzle checking (when optional drop sensor unit is installed)	110
Menu3: Test Print	112
Media Adjustment	113
Menu4: Setup menus.	115
Origin setting.....	120

Menu5: Roll Length Manage	122
Scan.....	124
Menu6: Printer Info.....	125

Maintenance

126

About Maintenance	127
Type of maintenance and frequency	127
Preparations for maintenance.....	129
What you need.....	129
Wearing protective equipment	130
About CR Maintenance	131
Regular Maintenance.....	132
Cleaning of the cleaning wiper	132
Cleaning of the parts around the capping unit	134
Cleaning inside the printer.....	136
Emptying waste ink tank	138
Maintenance based on your usage	140
When nozzle clogging occurred	140
Head cleaning	140
Nozzle clogging persists even after several head cleaning attempt.....	141
Cleaning of the parts around the print head	141
If severe nozzle clogging occurred	144
Little Charge.....	144
Soak Cleaning	145
Select Nozzle	148
When auto adjustment fails repeatedly in the Adjust Print calibration.	150
Clean the color sensor.....	150
Replace the consumable parts	152
Replace the flushing box pad.....	152
Step1. Checking steps	152
Step2. Replacing steps.....	153
Replace the Cutter	155
Replace the Cleaning Wiper.....	158

Moving or transporting the printer	161
Moving the printer	161
Preparation for moving the printer	161
Installation after moving	162
Transporting the printer	163
Long-term storage	164
Flushing ink	164
Initial ink charging after Longstore cleaning	169

When problems occur

173

Messages and Error Messages	174
Status messages	174
Error message display and remedies	176
Smartchip Recovery	179
Error requiring reboot	180
Troubleshooting	181
Trouble during installation / initial setup	181
Printer does not work at all after powered on	181
Cannot perform initial ink charging	181
Ink does not come out after initial ink charging	181
Nozzle clogging occurs after initial ink charging	182
Unable to connect to printer from MSM or RIP	182
Media-related problems	183
Printer does not work even after media is loaded	183
Media removed, torn, or wrinkled during media initialization	183
Printer does not detect media correctly	183
Media jams occur frequently	184
Media skews during printing	184
Printing problems	185
Data is sent but not printed	185
Carriage pauses at either side of the printer during printing	185
Media or print is smudged	186
Printing position is incorrect or there are areas that are not printing	186
Ink does not dry easily after printing	186
White or black line appears on the print	187

Printed lines are not aligned/ doubled, Print is faded/ bleeding.....	187
Printed color is not accurate	188
Nozzle clogging remains even after head cleaning.....	188
Media is jammed	189

Appendix

192

Specifications.....	193
Optional accessories / Consumable supplies	196
Revision history	197

For Safe Use



Safety Precautions

Symbols



In this document, information that must be followed is marked with following symbols to avoid risk of harm to human health or damage to the property.

Please understand the meaning of each mark and use this product safely and correctly.



■ The following signs are used to classify and explain the degree of harm or damage that may result from neglect of instructions or incorrect handling.

 Warning	Failure to follow the instructions could result in serious injury or death.
 Caution	Failure to follow the instructions could result in minor injury or damage to the whole or part of the product.

■ The following symbols are used to classify and explain the types of instructions that must be observed.

	Indicates an action that you must avoid.
	Indicates an important instruction that you must do.

■ Other symbols

	Provides information that require special attention or should be followed.
	Provides supplemental or reference information.
	Indicates the link to the reference section.





Note

For the name of each part marked with safety symbols, see [“Printer main components / Functions” P.23.](#)

Usage Precautions











When something wrong occurs

Warning



	<p>If something abnormal occurs such as smoke or unusual odor, turn off the power button and unplug the power cord.</p> <p>Keep using the product may result in electric shock or fire. Once you have confirmed that smoke is no longer being emitted, contact your local dealer or our service office. Never attempt to repair the machine yourself as it is dangerous.</p>
	<p>If a foreign object, water, or other liquid gets inside the product, immediately turn off the power button and unplug the power plug from the outlet.</p> <p>Keep using the product may result in electric shock or fire. After confirming there is nothing wrong, contact your local dealer. Never attempt to repair the machine yourself as it is dangerous.</p>
	<p>If ink, maintenance cleaning solution, or waste fluid gets on skin, immediately wipe it off with a cloth. Then wash with soap and plenty of water.</p> <p>If skin irritation or inflammation occurs, seek medical advice.</p>
	<p>If ink, maintenance cleaning solution, or waste fluid gets in eyes, immediately flush with plenty of water for 15 minutes. If eye pain or irritation is present, seek medical attention immediately.</p> <p>If left untreated, it may cause red eyes or mild irritation in the eyes.</p>
	<p>If ink, maintenance cleaning solution, or waste fluid is swallowed, do not induce vomiting. Immediately gargle and seek medical attention.</p> <p>Attempting to induce vomiting may cause vomit to enter the trachea.</p>

Product handling

Warning

	Do not touch the product when lightning starts. This could result in an electrical shock.
	Do not insert or drop metal or flammable objects into the printer through openings such as vent. This could result in fire or electric shock.
	Do not cover the product with a cloth or other material to block vent. If the vent is covered, heat may build up inside the product, resulting in fire.
	Do not touch the moving parts. This may cause injury or damage to the product.
	Do not sit or place heavy objects on the product. This could result in injury from a fall or tumble.
	Do not touch the media guide while printing or when the heater is in operation. The media guide gets hot, causing burn injury.
	Never modify the product or open any covers secured with screws. This could result in an electrical shock or damage to the printer. Also, modifying or disassembling the product will void the warranty.
	Do not pour flammable liquid on the media guide. This could result in fire.
	Be careful not to enter water inside the product. This could cause short-circuit.
	Immediately after printing, the media guide is hot. Allow the media guide to cool down before your work.

Caution















	Do not tilt or give any impact to the product. Doing so may cause the ink inside the printer to leak. Otherwise proper operation cannot be guaranteed after moving.
	Use the following safety precautions when handling the front cover or maintenance cover: <ul style="list-style-type: none"> • Avoid strong airflow from fan or air conditioner to covers when installing the product. It may accidentally close covers. • Check your surroundings for safety when opening cover. Cover may hit someone or something.

Important!

This product is equipped with interlocks to ensure safety use. It will interrupt operation if any cover is opened during operation such as printing or cleaning.

Power cords

Warning

	<p>Do not damage or modify power cord or power plug. Also, do not place heavy objects on it, heat it, or forcibly bend or pull it.</p> <p>This could damage the power cord, resulting in fire or electric shock.</p>
	<p>Do not use a power cord that is damaged, broken or core wire exposed.</p> <p>This could result in fire or electric shock.</p>
	<p>Do not plug the ground terminal into a power outlet.</p> <p>This could result in fire or electric shock.</p>
	<p>Do not allow metal or other objects to touch the blade of the power plug.</p> <p>This could result in fire or electric shock.</p>
	<p>Do not use power strips.</p> <p>This could result in fire or electric shock.</p>
	<p>Do not connect an earth wire to the following places:</p> <ul style="list-style-type: none"> • Gas pipe: It has potential risks of fire or explosion. • Earth wire of telephone cables or lightning rods: Large lightning current may flow when lightning strikes. • Water pipe and faucet: It may not function as a ground if a plastic pipe is connected to the pipe.
	<p>Do not connect or disconnect power plug with wet hands.</p> <p>This could result in an electrical shock.</p>
	<p>Be sure to use the designated power cord.</p> <p>Failure to do so could result in an electrical shock or fire. For the designated power cord, please contact your local MUTOH dealer.</p> <ol style="list-style-type: none"> 1. Use a power cord with protective ground terminal and make sure to plug in securely into the outlet. 2. Use a power cord which meets the safety standard, power source, voltage and plug shape of the country to use the product.
	<p>Use the product within the designated power specification range.</p>
	<p>Plug the power cord into a power outlet near the product.</p> <p>This equipment should be installed near the power outlet and should be easily accessible in case of emergency.</p>
	<p>Use the cord clamp to secure the power cord.</p>
	<p>Insert the power plug blade securely.</p> <p>Incomplete insertion may cause fire or electric shock.</p>
	<p>When unplugging the power cord, be sure to hold the plug and pull it out.</p> <p>Pulling on the power cord may damage the cord, resulting in fire or electric shock.</p>
	<p>Clean the power plug regularly with a dry cloth.</p> <p>Moisture adhering to accumulated dust may cause a short circuit. This could result in fire or electric shock.</p>

Power cords



Unplug the power plug from the outlet when not using the product for an extended period of time.

Dust buildup on the power plug may cause fire or electric shock.



Plug the power cord into the wall outlet that has the earth connection and be sure to connect the earth wire.

Failure to connect the earth wire may cause an electrical shock or fire.

Make sure to connect an earth wire to the earth connection that meets the following requirements:

- Earth terminal of power socket
- An earth wire with a copper plate which is buried more than 650 mm deep into the ground



Caution



Use a power outlet and breaker which satisfy the power requirement of the printer.

The breaker may shut down if it does not meet the power requirements.

Printer installation and moving

Warning



Choose the location which satisfies the requirements below:

1. The floor must be level
2. Avoid vibration from the neighboring devices
3. Low humidity and free from dust
4. Less chance of temperature and humidity changes
5. Avoid direct sunlight
6. Avoid water
7. Avoid direct air (including air conditioning) onto the printer
8. Low levels of electromagnetic waves



Install in the area that can be ventilated and ensure that the work area is well ventilated.

Odor of ink could have adversely impact on health. If you experience headache or feel dizzy or dull, stop your work and get to fresh air. If nausea persists, seek medical advice. As a guide, Mutoh recommends you to change air 5 to 10 time per hour or use local ventilation system.



Before taking out the printer from the packaging box, make sure to remove the plastic sheet wrapped around the printer first.

Failure to do so may cause slip, damaging printer.



Do not install the product in locations where children are likely to be present.

Caution



At least four people are required for unpacking and moving the printer. When moving, keep the printer level.



Empty the waste ink tank even when moving for a short distance.

Failure to do so may result in damage to the printer.



Wearing safety shoes is recommended for moving this product.



When transporting this product, please consult your local MUTOH dealer.

Important!

The following space is required for installation.

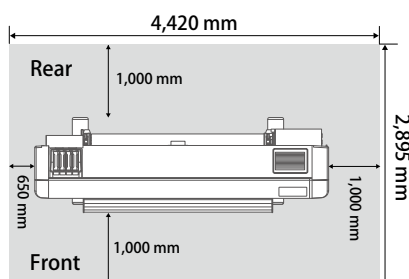

Printer size









Width x Depth: 2,770 mm x 895 mm

Height: 1,611 mm *¹

*¹ With ink bag case (1,000 ml) installed. A minimum of 1,760 mm height is required for installation space.





About Maintenance

Caution











   	<p>When cleaning, make sure to wear protective equipment (gloves, goggles or eye protection, protective clothing, protective mask).</p>
	<p>Follow these precautions when cleaning:</p> <ul style="list-style-type: none"> • Do not touch the tip of cleaning stick with finger. Finger oil may cause print head malfunction. • Never put water on the tip of cleaning stick. This will cause the print head damage. • Use a new cleaning stick. The reuse of used cleaning sticks may cause print head malfunction. • Allow the media guide to cool down before your work. Immediately after printing, the media guide is hot. Allow it to cool down for at least 30 minutes and then perform maintenance.
	<p>Never touch the print head nozzles when cleaning the parts around the print head. This could cause damage to the print head.</p>
	<p>Do not touch the cleaning wiper and the print head capping unit with bare hands when cleaning the wiper. If finger oil gets on this, head cleaning cannot be performed properly.</p>
	<p>Do not use volatile chemicals such as thinner, benzine, alcohol, etc. This may cause damage to the paint or plastic cover.</p>
	<p>Avoid the following actions when ink filling is in progress.</p> <ul style="list-style-type: none"> • Turn off the printer or unplug the power cord. • Open the front cover or maintenance cover • Raise the pressure rollers • Move the printer

Ink and waste fluid

Warning

	<p>The safety concerns involved with using and handling of ink and waste fluid are detailed in the Safety Data Sheet (SDS). Make sure to read the SDSs when handling these liquid.</p> <p>Download the latest version of SDSs from our website.</p>
	<p>Waste fluid collected from the product is classified as waste oil of industrial waste. You are obligated to properly dispose of waste fluid from the printer in compliance with Wastes Disposal and Public Cleansing Act and local ordinances. Delegate disposal to an industrial waste disposal contractor.</p>
	<p>Do not bring fire to the work area.</p> <p>There is a risk of fire from ink or waste fluid.</p>
	<p>Keep the ink, cleaning solution and waste fluid away from fire and heat and store in a cool, darkplace.</p>

Caution

	<p>When handling ink or doing a task that you may come into contact with ink (such as cleaning print head, capping station, wiper), make sure to wear protective equipment (gloves, goggles or eye protection, protective clothing, protective mask).</p>
	
	<p>Be careful ink does not get into eyes or skin when you handle ink bag. If ink gets in eyes or on skin, immediately flush with water.</p>
	<p>If left untreated, it may cause red eyes or mild irritation in the eyes. If there are some problems, immediately seek medical attention.</p>
	<p>Use MUTOH genuine ink.</p> <p>This product is designed to deliver best performance by using MUTOH genuine ink. The use of non-genuine ink may adversely affect the product as well as print quality. The warranty does not cover such use.</p>
	<p>Use inks within its shelf life.</p> <p>The use of expired ink can lead to jetting failure or cause damage to the product.</p>
	<p>When expired, replace with a new one even if ink remains in the ink bag.</p> <p>Dispose of expired ink as industrial waste. Put the emptied ink bag in a plastic bag and dispose of it according to the local regulations.</p>
	<p>Do not allow waste fluid collected from this printer to reach sewage or natural water systems.</p>
	<p>Do not mix waste fluids with any other substances or liquid not even in small amounts.</p> <p>Mixing with other chemicals (such as oxidant) will cause heating.</p>
	<p>Do not disassemble or give strong impact to the ink bag.</p> <p>Doing so may cause ink leakage.</p>

Warning labels

Warning labels are affixed to the hazardous area of the printer. Read and follow the instructions on the labels. If the label came off or got dirty, please contact your local MUTOH dealer for replacement.

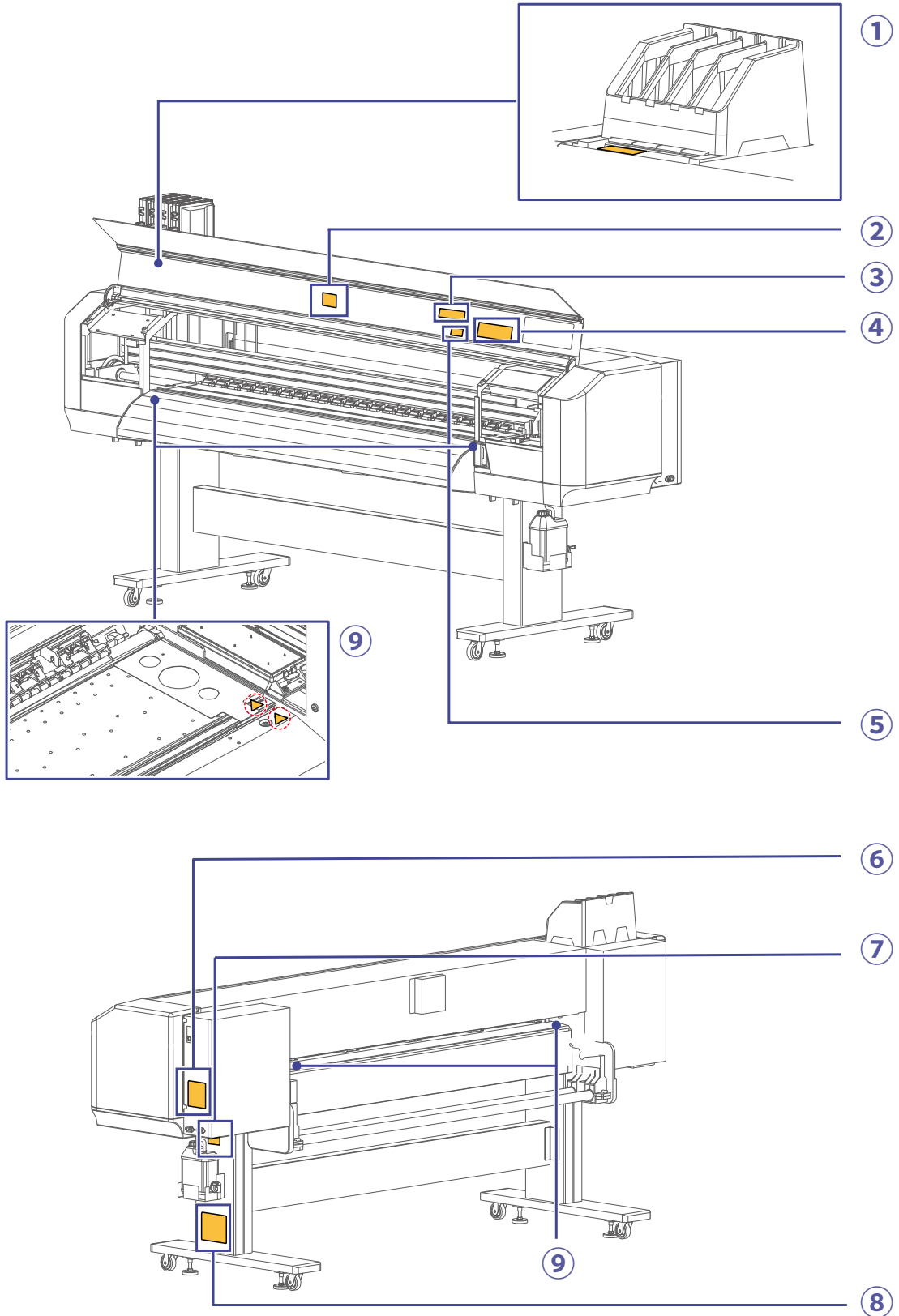

Type of labels

Name / Meaning

①



Personal Protective Equipment Label

Wear protective equipment when handling ink.

②

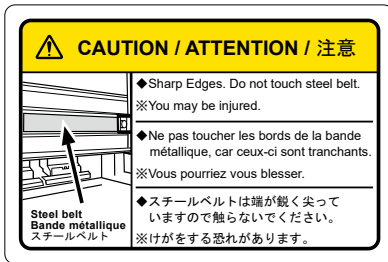

Steel Belt Caution

Do not touch this part. It may cause injury.

③



Cutter Caution

Do not place fingers near the cutter. Risk of injury from blade contact.

④



Front Cover Caution

Follow the instructions on the label.

⑤

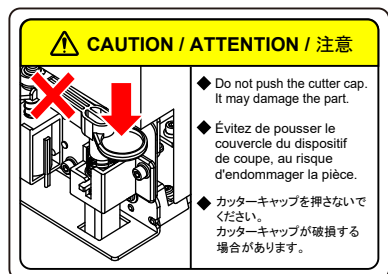

Cutter Cap Caution

Do not push the cutter cap. This could damage the cap.

⑥

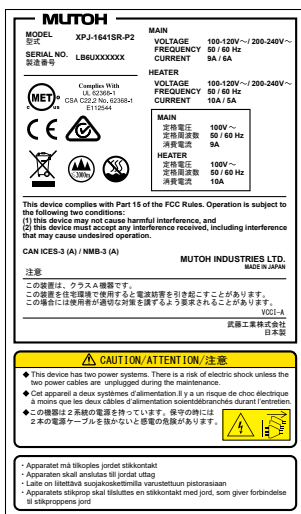



Rating Plate

Provides model, serial number, electrical ratings, certification and notification information.

Instruction Labels

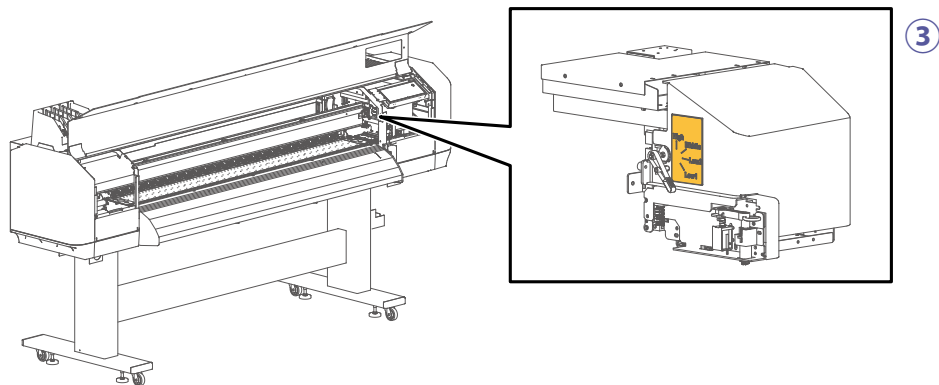
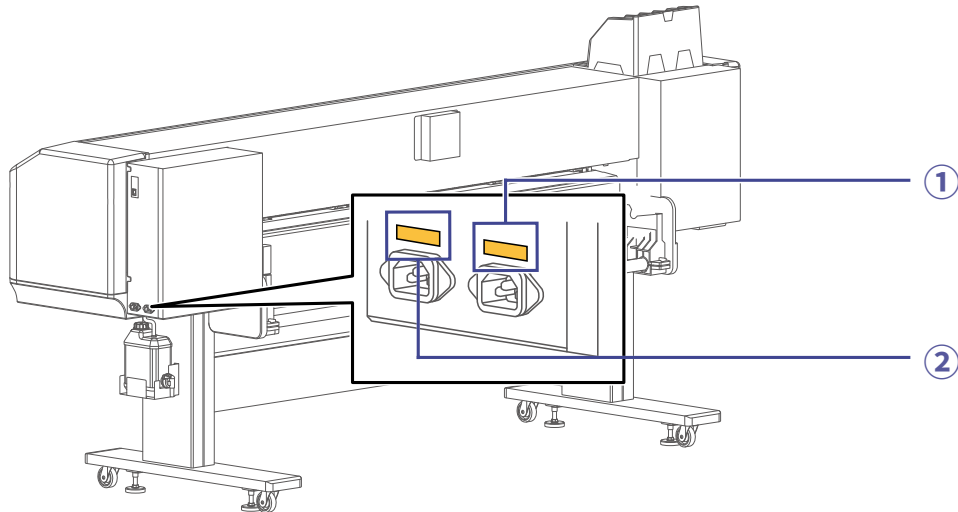
Instruction labels are affixed where special attention for operating this product is required. The contents of each label are shown here.

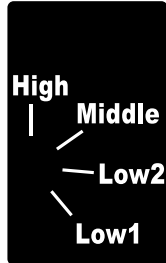

	Type of labels	Name / Meaning
①		AC Inlet Label (MAIN)
②		AC Inlet Label (HEATER)
③		PG Label <ul style="list-style-type: none"> • Indicates the height of print head.

1 Before Use

Printer main components / Functions	23
Computer requirements	29
System configurations	30
Launching/ Opening/ Exiting MSM	31
Printing area	32
Supported media	33
Precautions	35

Printer main components / Functions

Front view

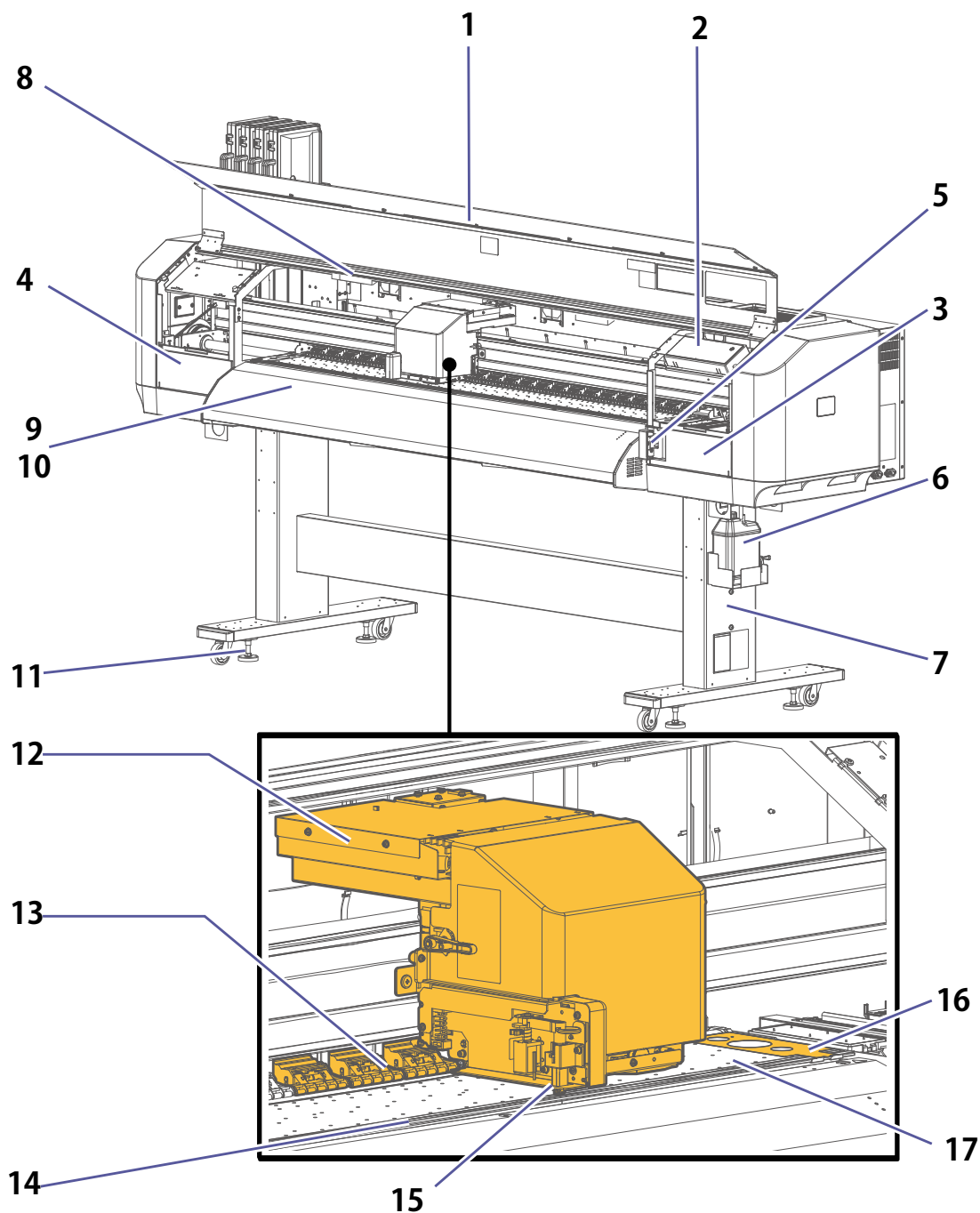

1	Front cover	Opens and closes when loading media or removing jammed paper. Normally it is closed.
2	Printer control panel	→ “Printer control panel” P.27
3	Maintenance cover R	Opens and closes when cleaning or replacing consumable parts. Normally it is closed.
4	Maintenance cover L	
5	Media feed lever	Holds down or releases media. Push the lever all the way in to hold down the media. The holddown pressure can be changed between "Normal" and "High" using this lever.
6	Waste ink tank	Collects waste ink and cleaning solution from the printer. Empty the tank before it becomes full.
7	Stand	This supports the main body of the printer.
8	Internal LED lights	Use it for inspecting inside of the printer or print results.
9	Media guide	Roll media path.
10	Heater	A heater is built inside the media guide to dry the ink.
11	Adjuster	This is used to adjust the height of the printer or prevent shaking.
12	Carriage	The print head is built in. It moves left and right during printing.
13	Pressure rollers	Holds down the entire media while printing. The slide lock lever on each pressure roller can be used to reduce or cancel the holddown pressure.
14	Media cut groove	Use it to cut the media straight.
15	Cutter	Use this when cutting media automatically.
16	Edge holder	Place it on both ends of the media to prevent the media from lifting.
17	Platen	Media is printed on here. It has a vacuum fan inside.

Rear view

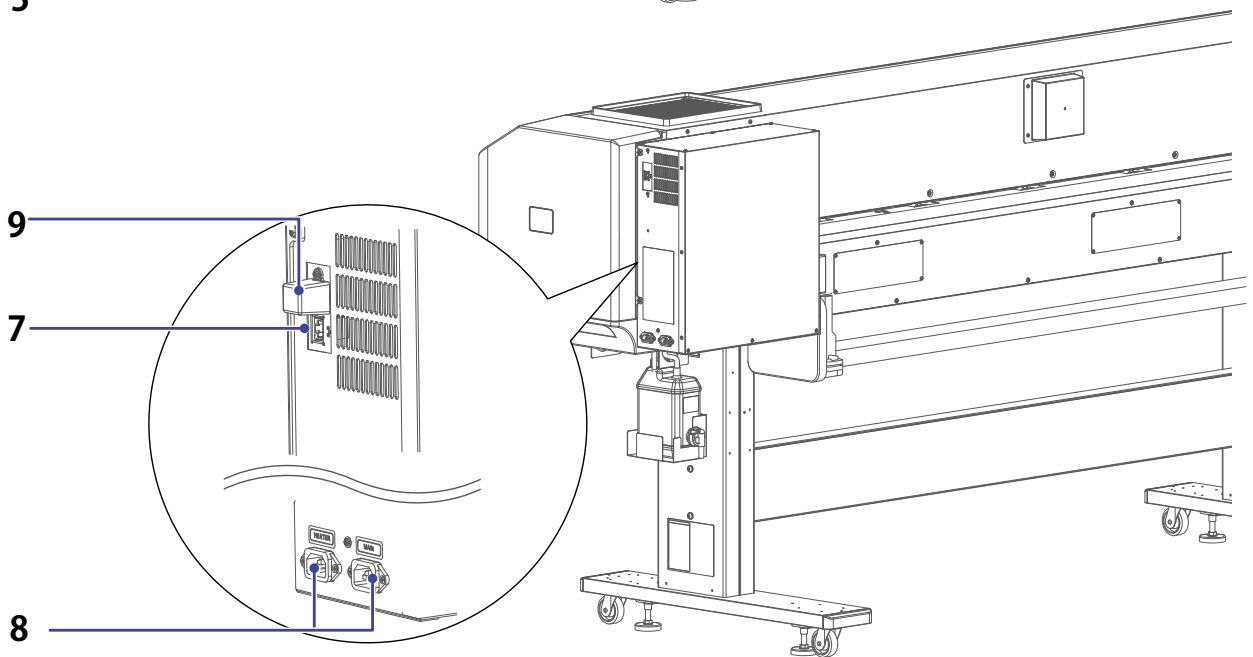
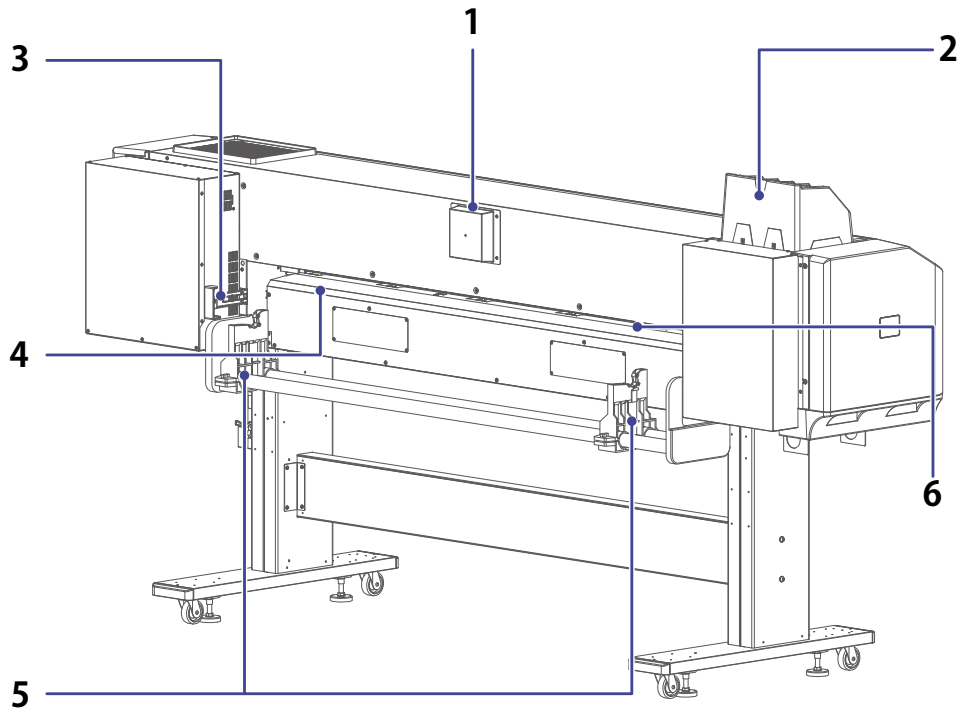

1	Exhaust fan	Remove exhaust from inside the printer.
2	Ink slots	Insert ink into this slot. Ink color arrangement is shown below.
3	Media feed lever	Holds down or releases media. This lever is interlocked with the media feed lever on the front side.
4	Media guide	Roll media path.
5	Roll media holder	Load a roll media onto the roll media holder. Attach the media flange to the roll media and load it to the roll media holder.
6	Media feed slot	When loading media, insert the leading edge of media into this slot and pass it to the front side.
7	Network interface cable connector	Connect an Ethernet cable and connect the printer to the computer.
8	AC inlet	Connect the power cord.
9	Take up unit connector (optional)	The connector used to connect the take-up unit to the printer.

Printer control panel



How to use the printer control panel

The printer has a touch-screen panel. The active keys are lit up on the panel for guidance.

- Tap: Lightly touch the key and immediately release your finger.
- Long touch: Press and hold the key.

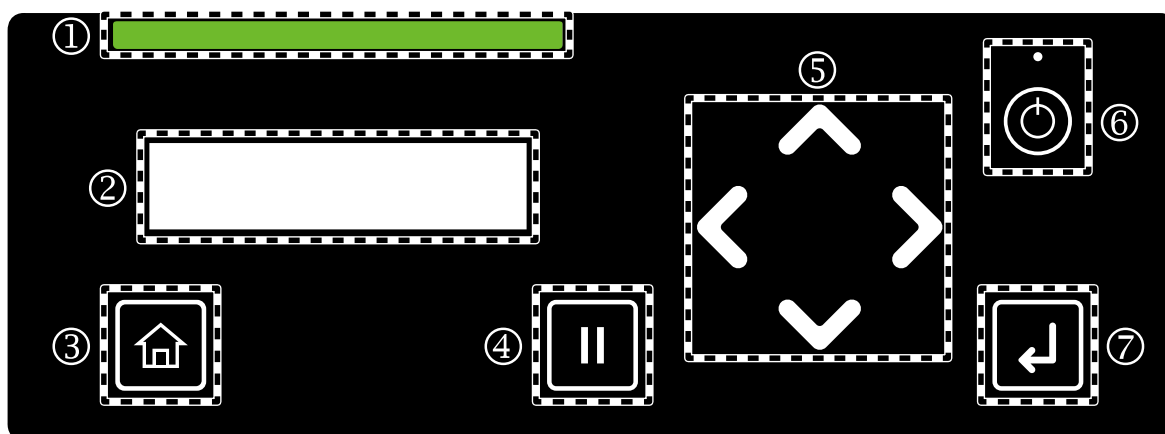
Name of parts / Functions



①	Status light	Indicates the printer status and error by LED light. <ul style="list-style-type: none"> • Working normally: Solid green • Error state: Solid red
②	Display	Displays printer status, setting menus, errors, etc.
③		[Home] key: Select this to access to or exit the setup menu.
④		[Cancel] key: <ul style="list-style-type: none"> • Tap to pause printing. Tapping the key again while pausing will resume printing. • Tapping the key while no printing is performed will cut the media.
⑤		Arrow keys: In the Setup menu, use these keys to select a menu or enter a value. <ul style="list-style-type: none"> • [▲] key: Scroll up the menu list. • [<] key: Return to the previous menu without saving the change. • [>] key: Go to the next level menu. • [▼] key: Scroll down the menu list.

6

**Power button:**

- Pressing for more than 2 seconds while the power is off will turn on the power. The small LED above the button will turn on white.
- Pressing for more than 2 seconds while the power is on will put the printer in sleep mode. The small LED above the button remains on white.
- Normally use the setup menu on the control panel to turn off the power. The LED above the power button turns off when the power is off.

→ [“Turn off the printer” P.42](#)

Note

⏻ mark means standby. The printer consumes a small amount of power unless the power cord is disconnected, even when the white LED above the button is off. In this document, this state is referred to as “power being off” .

7

**[Enter] key:**

Tap to confirm the menu or the value selected.

Direct keys

Tapping the following keys while **[Print Ready]** is displayed will provide a shortcut to a specific menu.

⊙ [<] key

Tap to print the nozzle check pattern F.

→ [“Run a nozzle check” P.56](#)

⊙ [>] key

Tap to access the following maintenance menu.

→ [“Perform a head cleaning” P.58](#)

→ [“About CR Maintenance” P.131](#)

→ [“Soak Cleaning” P.145](#)

⊙ [^] / [v] key

Tap to feed media.

→ [“Feeding media” P.76](#)

⊙ [Cancel] key

Tap to cut media.

→ [“Cutting Media” P.80](#)

Computer requirements

Important!

Make sure your computer meets the following requirements:

- OS: Windows 11
- CPU: Intel (R) Core (TM) i5 or more
- Memory: 16GB or more
- Network: Use a Gigabit Ethernet-compatible network port and Gigabit Ethernet cable of Category 6 or higher.

Note

- The OS support period of MUTOH software follows the Microsoft support lifecycle policies.
- When using RIP software, please also check the system requirements of your RIP software.

System configurations

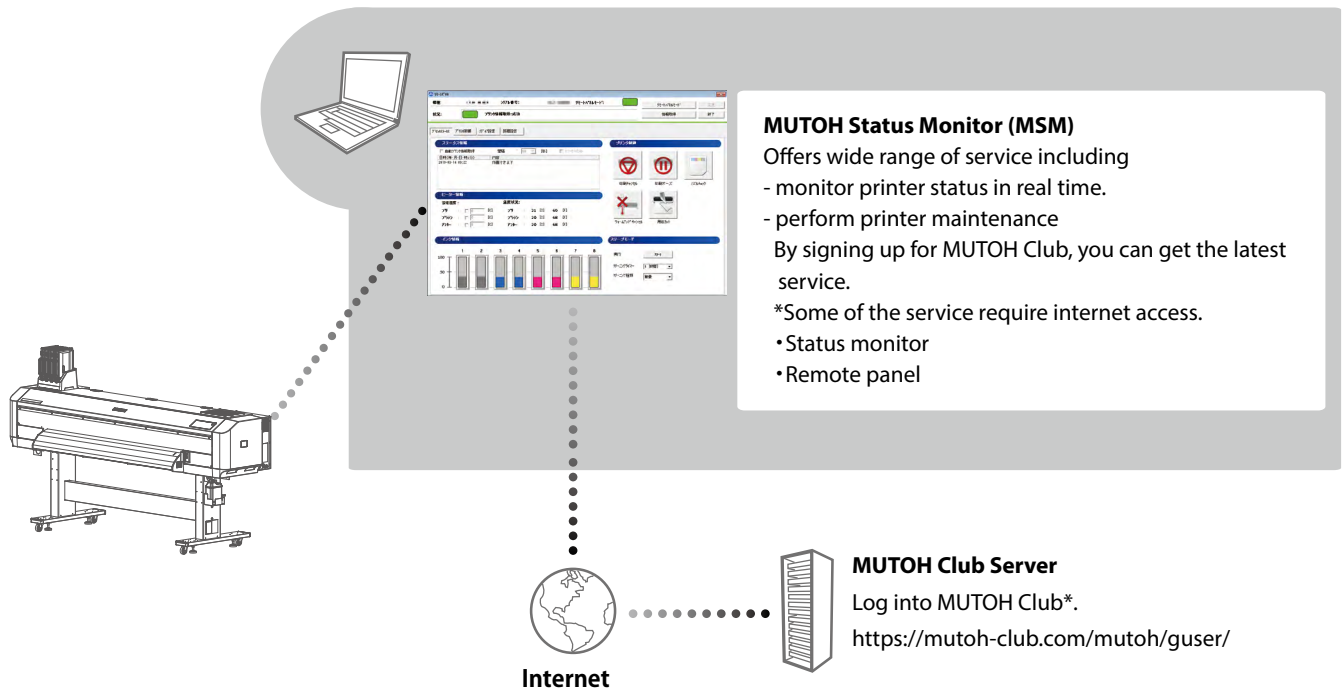

*MUTOH Club

By signing up for MUTOH Club, it offers free useful contents including

Key features:

- download the latest version of application, operation manual
- download media profile
- check printer status (when using MSM's printer information service)

< If you are using RIP software other than VerteLith >

To maximize your printer's performance, use the MUTOH Status Monitor (MSM). You can download the latest version of MSM from MUTOH Club.

To use Mutoh Print Server (MPS) *2, specify the output port of RIP software to MPS.

Note

*2 MPS is an application that improves performance of MUTOH printer. It functions as preprocessing software and supports printer function through Ethernet connection. For details of recommended network environment and setup, see "MUTOH Status Monitor Operation Manual".

Launching/ Opening/ Exiting MSM

Launching MSM



Double-click the MSM icon on the desktop.

Note

Launching from the Windows Start menu

- From the **[Start]** menu, click **[All Programs]** (or **[All Apps]**) - **[MUTOH]** - **[MUTOH Status Monitor]**.

Opening MSM

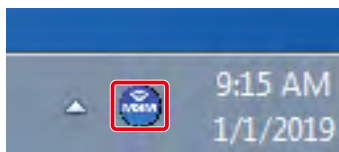

Double-click the MSM icon in the task tray.

Displaying remote panel

The remote panel allows you to view the printer status and remotely operate your printer.

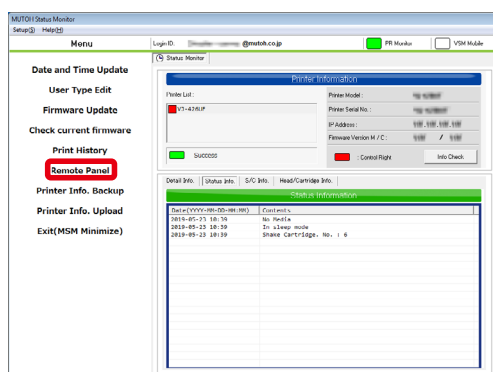

Click the Remote Panel.

- The remote panel opens.

Exiting MSM

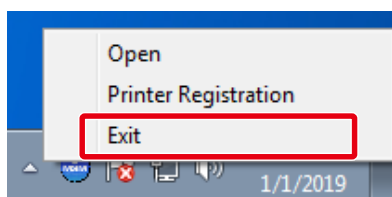

Right-click the MSM icon in the task tray and click **[Exit]**.

Note

While using your printer, do not exit MSM. To close the MSM window, click **[Settings]** - **[Close]** on the menu bar.

Printing area

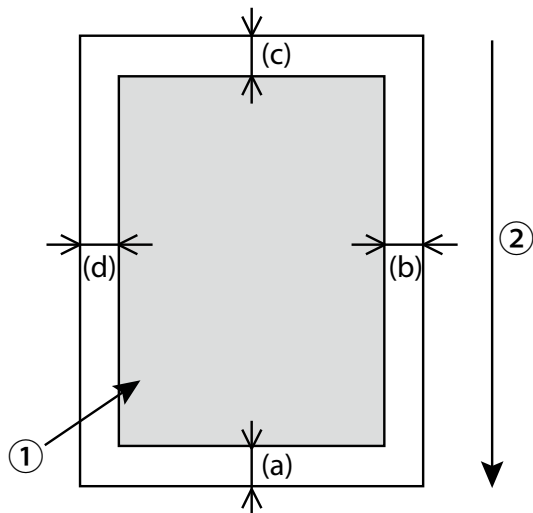

(a): 5 mm*¹

(b): 5 mm to 25 mm*²

(c): 5 mm

(d): 5 mm to 25 mm*²

①: Printable area

②: Media feeding direction

*¹ Margin will be 15 mm in the following cases:

- The first printing after media initialization
- When feeding the media backward by using **[▲]** key

The margin will be 40 mm in the following cases:

- When the Media Initial menu is set to **[Top&Width]**
- After cutting media

*² Margin can be changed from the Side Margin menu.

Supported media

Media that meets the requirements below can be used on this product.

Media size

Roll media outer diameter	Up to 200 mm
Paper core diameter	2 inches: 50 mm to 52 mm 3 inches: 75.5 mm to 79 mm
Weight	Up to 30 kg
Width	500 mm to 1,625 mm
Recommended media thickness	Up to 1.0 mm

Important!

- The factory default print head height is set to “Low1” .
- In the “Low1” setting, media up to 0.3 mm thick can be loaded on the printer.

Note

For recommended media, please contact your local MUTOH dealer.

Media handling cautions

Note the following points when handling media.

- Media should be used in an appropriate environment.

The temperature and humidity suitable for printing are as follows:

Recommended printing environment	Temperature: 22°C to 30°C
	Humidity: 40 % to 60 %, non-condensing
Change rate	Temperature: within 2 °C per hour
	Humidity: within 5 % per hour

- Use media with no fold, scratch, torn or winding curl.
- The size of media may change at a certain rate due to humidity fluctuation in the printing environment.
Before using media, rest it for 1 hour in the printing environment to adapt it to the environment. Printing without adapting media to the printing environment may cause media jams due to skew or wrinkles in the media. It also has a negative impact on print quality.
- When using the printer in a low-humidity environment, the cut media may stuck and may not dome down.
In such cases, cut the leading edge of media, open the front cover and then remove the media.
- Do not touch the print side of media.
Moisture and oil on your hands can affect print quality.
- Do not leave media loaded for long periods of time.
Some media has winding curls, causing media lifting, media jams or degradation of print quality. Avoid using such media, especially during winter or in dry conditions.
- Do not discard the original packaging box and plastic bag of roll media. You will use them for storing media.

Precaution on storing media after use

When storing roll media after use, follow these precautions to avoid print defects caused by wrinkles;

- After removing a roll media from the media flange, wind it back onto the roll properly and put it in the original plastic bag. Then store it in the package it came in.
- Avoid high temperature, high humidity, and direct sunlight when storing media.
- Keep the media dry.

Precautions

Please use this printer regularly

Mutoh recommends you to use this printer at least once a week.

If the printer is not used for a long time, the print head could get clogged, causing damage to the printer.

Please handle ink bag carefully

- Before using the ink bag for the first time, be sure to read the Safety Data Sheet (SDS) and carry out any work.

- Do not disassemble the ink bag.

When disassembled, the ink may get into the eyes or on the skin, causing irritation or allergic reactions.

- Wear gloves, protective glasses, and protective mask when handling ink bags.
- Be careful ink does not get into eyes or skin when you handle ink bag.

If ink gets in eyes or on skin, immediately flush with water. If left untreated, it may cause red eyes or mild irritation in the eyes. If there are some problems, immediately seek medical attention.

- Do not drop the ink bag or hit it hard.

Ink may leak.

- Use inks within its shelf life.

Dispose of expired ink as industrial waste. Put the emptied ink bag in a plastic bag and dispose of it according to the local regulations.

- Use MUTOH genuine ink.

This product is designed to deliver best performance by using MUTOH genuine ink. The use of non-genuine ink may adversely affect the product as well as print quality.

Please conduct maintenance regularly

This product requires regular user maintenance.

- Run a nozzle check before and after printing. If the nozzle is clogged, perform a head cleaning.
- Clean the cleaning wiper once a week.
- If you are not using the printer for an extended period*, run a head cleaning once a week. If you are unable to perform head cleaning, perform “Longstore” maintenance. (*“If you are not using the printer for an extended period” means you are not using the printer for one week to one month.)
→ **“Long-term storage” P.164**
- Clean the interior of the printer at least once a month.
- Check the waste ink tank regularly and drain the waste fluid before it becomes full.

Some parts need to be replaced periodically

In this product, the following parts must be replaced after a long-term use.

- **Parts that need to be replaced by the user:**
Flushing box pad, cutter, cleaning wiper
- **Parts that need to be replaced by service personnel:**
Various motors, various pumps, print heads

2 Basic Operations

Printing workflow	38
Power Operation	39
Load the media into the printer	43
Nozzle check and head cleaning	56
Calibrating your printer	59
Settings depending on media	60
Start printing	71
Operating from the printer control panel	76
Checking ink level and replacing ink bag	83

Printing workflow

The basic workflow for printing is as follows:

- 1** Turn on the printer.
→ [“Turn on the printer” P.39](#)
- 2** Load media into the printer.
→ [“Load the media into the printer” P.43](#)
- 3** Run a test print. (Run a nozzle check and perform cleaning if needed)
→ [“Nozzle check and head cleaning” P.56](#)
- 4** Calibrate your printer. (When necessary)
→ [“Calibrating your printer” P.59](#)
- 5** Change printer settings depending on media.
→ [“Settings depending on media” P.60](#)
- 6** Print a design.
 - We will introduce the printing procedure using MUTOH RIP software “VerteLith”.→ [“Start printing” P.71](#)

Power Operation

Turn on the printer

- 1 Close the front cover.
- 2 Press the power button on the control panel for more than two seconds.
 - The LED above the power button lights up.
 - Printer initialization begins.

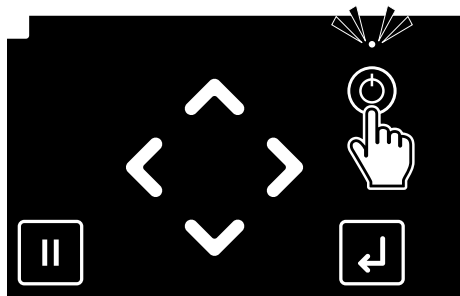

Note

Once the power LED lights up, release the power button.

Sleep Mode

Do not power off the product. Make sure to put into sleep mode while not in use. Failure to do so may result in ink coagulating, causing print defects or printer failure. Failure to do so may result in ink settling, causing print defects or printer failure. While in sleep mode, the printer performs automatic head cleaning regularly. The LED above the power button lights up and key operation is invalid except [**Enter**] key.

When you need to turn off the printer for maintenance, operate from the setup menu on the control panel.

→ “Turn off the printer” P.42

Important!

If any of the following conditions occur during sleep mode, head cleaning will not be performed (The printer will stop operation during head cleaning). When restored to normal conditions, head cleaning will resume.

1. Front cover or maintenance cover is open.
2. The pressure rollers are in up position.
3. Waste ink tank is full.
4. Ink bag case is removed
5. Smart chip card is removed.
6. A non-genuine smart chip card is inserted.

Start the sleep mode

- 1 Ensure that printing is complete and media has been removed.
- 2 Press the power button on the control panel for more than two seconds.

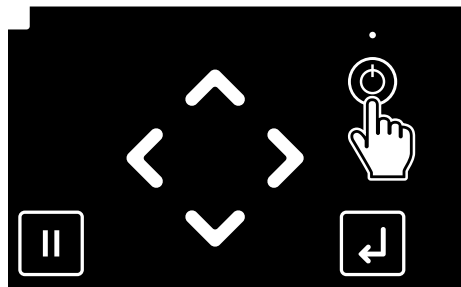

- [**Please wait**] appears.
- Then the following message appears and the printer starts sleep mode.

Sleep Mode
End -> Enter

Note

Sleep mode cannot be started in the following cases:

- A error is occurring (Ink End, No Bag, Full Waste Ink Tank, Cover Open, etc.)
- Printer is running (during Media Initial, printing, etc.)

■ When unable to start sleep mode

- **[Clear the error]** appears: Clear the error that is being displayed and then put the printer into sleep mode.
→ **“Messages and Error Messages” P.174**
- **[Unable to Enter to Sleep Mode]** appears: The printer is in operation. After the printer has finished its operation, put it into sleep mode.

Note

- You can also put the printer into sleep mode from the setup menu of the printer control panel. Change the type and interval of automatic head cleaning to be performed during sleep mode from the setup menu of the printer control panel.
→ **[Maintenance] P.107 > [Sleep Mode] P.109 > [Cleaning Setting] P.109 , [Start] P.109**
- The printer is automatically put into sleep mode if no printing is performed for certain period. You can change the timer to automatically enter to sleep mode using the setup menu on the control panel, but a default setting 4 hours is suggested.
→ **[Maintenance] P.107 > [Sleep Mode] P.109 > [Auto Sleep Timer] P.109**

Wake up from sleep mode

- 1 While the following message appears, tap **[Enter]** key.



Sleep Mode
End → Enter

The printer wakes up from sleep mode and **[Print Ready]** appears on the panel.

Turn off the printer

Normally use the setup menu on the printer control panel to turn off the printer.

1 Ensure that printing is complete and media has been removed.

2 Tap **[Home]** key.

3 Access the “Power Off” menu.

Menu flow



- **[▲]** / **[▼]** key: Select a menu item.
- **[>]** key: Enter the menu.

4 Tap **[>]** key.

5 Use **[▲]** / **[▼]** key to select **[Power Off? Yes]** and tap **[Enter]** key.

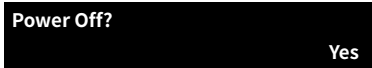

- The printer begins powering off.
- The LED above the power button turns off.

Important!

Only in the following cases, you can power off the printer by pressing the power button for more than 2 seconds.

- When an error requiring reboot occurred
- Ink has not been filled in the printer
- During printer activation
- After the printer firmware has been updated in MSM

Procedure

1. Press the Power button for more than 2 seconds.
 - The printer begins powering off.
2. When **[Power Off]** appears, release the Power button.
 - The LED above the power button turns off.

Load the media into the printer

Loading the media into the printer

Important!

Depending on the size of media to be loaded, two or more people are required for this task.

Step 1. Attach the flanges to the media

1 Prepare the required items.

- Roll media: 1 piece
- Media flange: 2 pieces

2 Change the flange adapter depending on the size of paper core of roll media.

■ When you are using 2-inch core roll media;

- Remove the 3-inch adapter from the media flange.
 - ①: Pull two tabs on the adapter outward, then remove the adapter.
 - ②: Pull three tabs on the adapter outward, then remove the adapter.

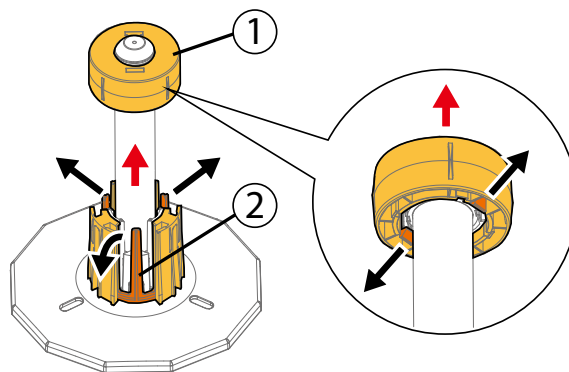

Note

- If unable to remove ② adapter, turn the handle on the flange anticlockwise to loose, then remove it.

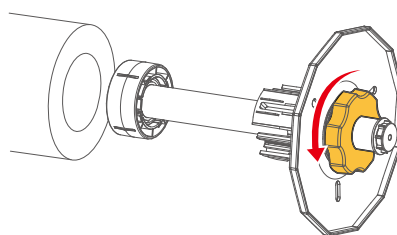

- If you are using 3-inch core roll media, skip this step.

■ **When replacing 2-inch core roll media with 3-inch core roll media;**

- Attach the 3-inch adapters to the media flange.
 - ① : Align the adapter tabs (x3) with the notches at the base of the flange to click into place.
 - ②: Align the adapter's inner notches (x4) with the protrusions (x4) on the flange tip to attach.

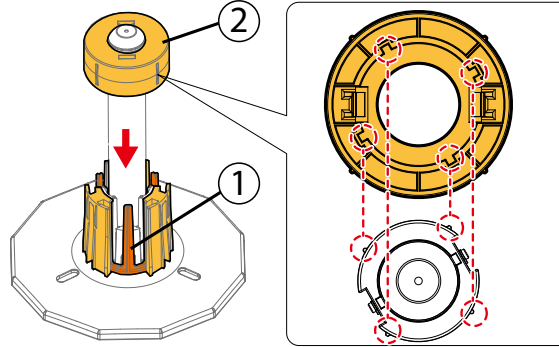

Note

If ② adapter is installed without aligning the position, it will not be secured properly.

3 Push the media flange (x2) into both ends of the media core.

- Twist the flange handle anticlockwise to unlock it.

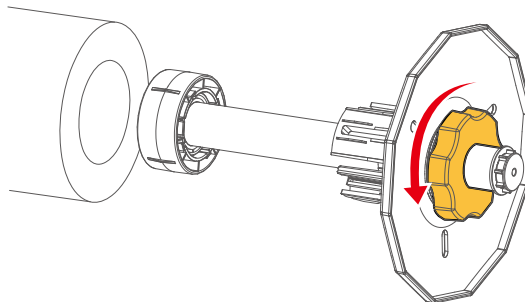

4 Twist the flange handle clockwise to lock the flange.

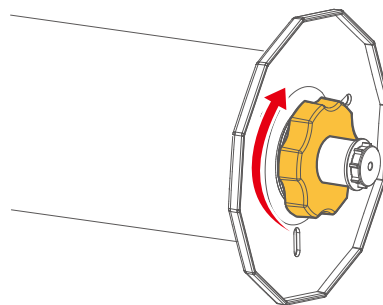

Important!

Check that the flange is firmly locked. If not, the media can be removed from the flanges while printing, affecting the print quality.

Step2. Enable torque on media holders

If you want to apply torque to the media holders, follow these steps.

- 1** Prepare the required items.
 - Phillips-head screwdriver
- 2** Twist the knob bolt on the left and right media holders anticlockwise to loosen.

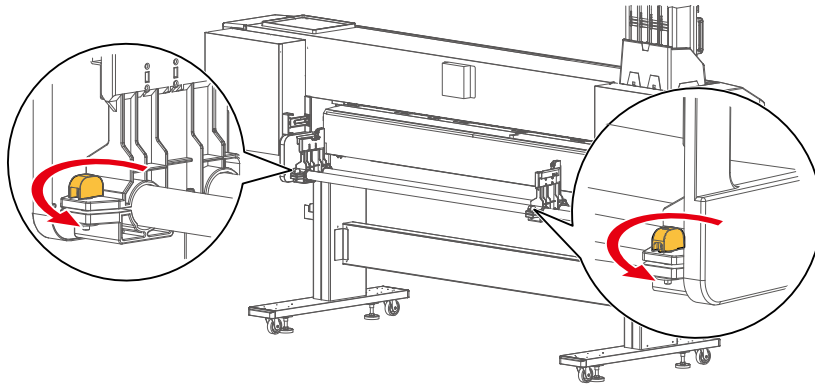

- 3** Slide both left and right media holders about 30 cm towards the center of the slider for easy access.

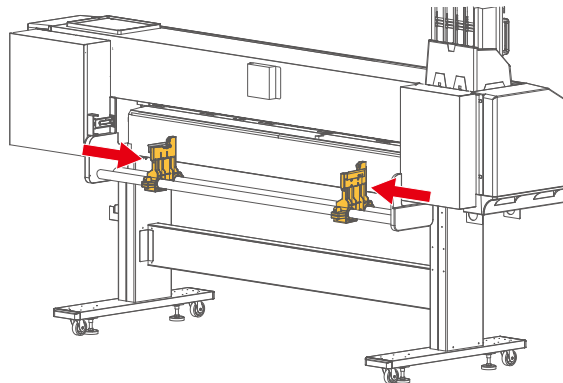

- 4** Tighten the knob bolts on both media holders.
- 5** (When looking from the rear side of the printer) Use the screwdriver to loosen the screws securing the roller shaft guide plate to the right media holder.

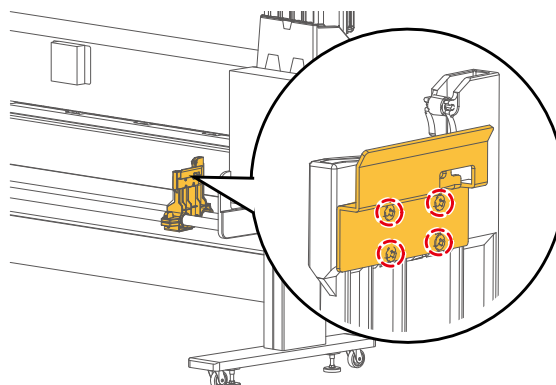

- 6** Slide up the roller shaft guide plate as far as it will go and tighten the screws.

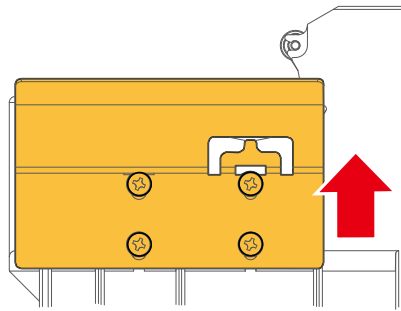

Roll shaft guide plate (right)

- 7** Do the same for the left media holder to slide up the roller shaft guide plate as far as it will go and tighten the screws.

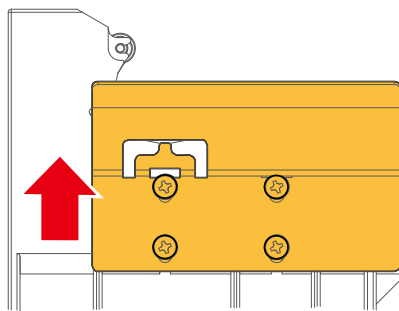

Roll shaft guide plate (left)

- 8** Loosen the knob bolts and slide back both media holders to the original position.

- 9** Tighten the knob bolts on both media holders.

Step3. Placing the media onto the media holder

- 1** Twist the knob bolt on the right media holder anticlockwise to loosen.

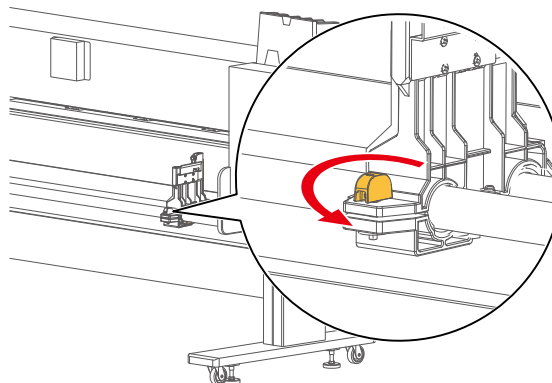

2 Place the roll media onto the left media holder.

Carefully and gently place it on the holder following the steps below.

- a. Place the tip of the flange between the roller shaft guide plate (①) and the media holder (②) as shown in the illustration.

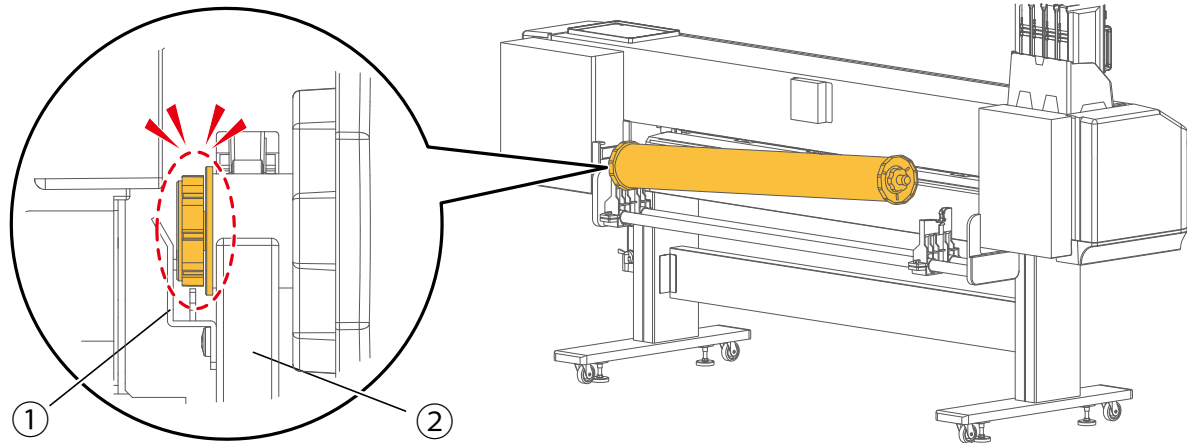

- b. If you have enabled torque, check the following.

- ①: When looking from the side, check that the protrusion on the roller shaft guide plate is fitted in between two protrusions on the flange end cap.
- ②: When looking from the rear side of the printer, check that the flange end cap is properly placed on the protrusion on the roller shaft guide plate.

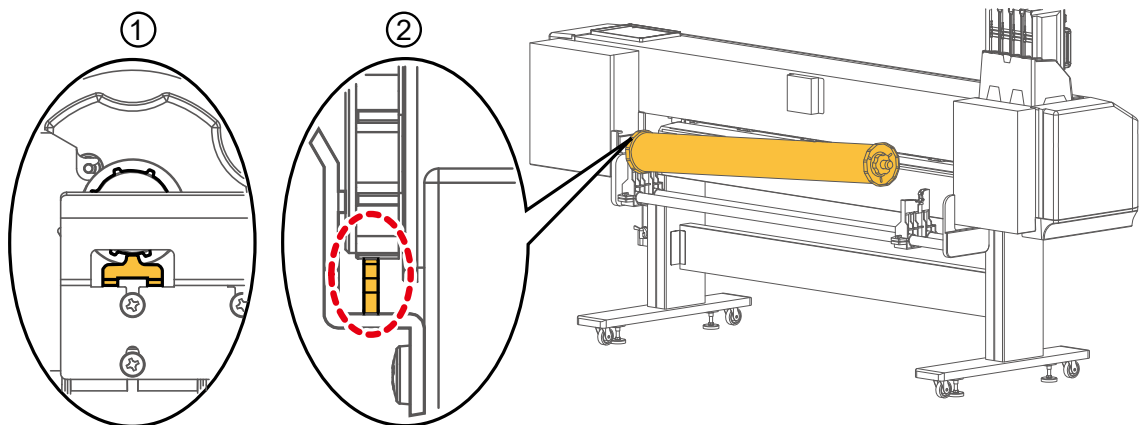

Important!

- Do not drop or apply excessive impact while placing the media. This will cause damage to the part.
- When you adjust the position of the media holder (left), do not move it more than 450 mm away from the left-hand end. The printer will not be able to detect media.

3 Place the roll media onto the right media holder.

Carefully and gently place it on the holder following the steps below.

- a. Move the right side of the media holder to align with the media.
- b. Place the tip of the flange between the roller shaft guide plate (①) and the media holder (②) as shown in the illustration.

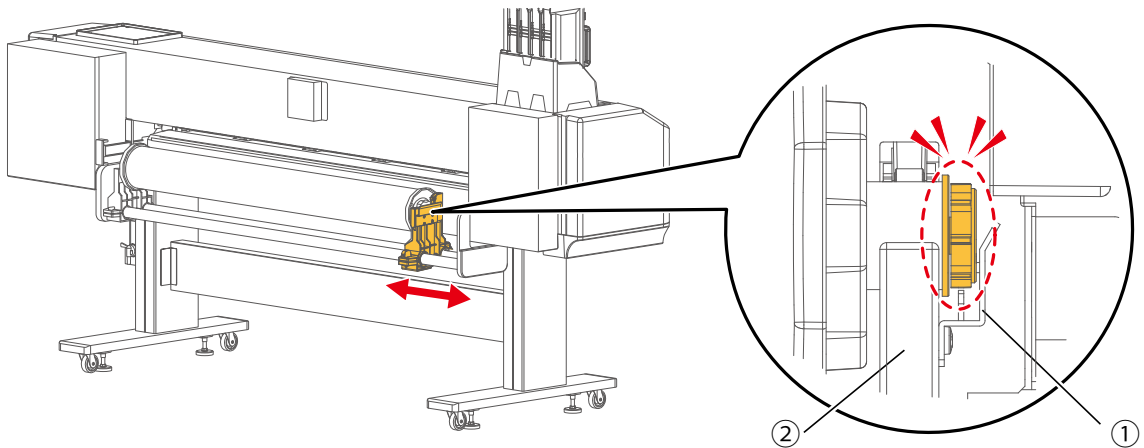

Important!

Do not drop or apply excessive impact while placing the media. This will cause damage to the part.

- c. If you have enabled torque, check the following.
 - ①: When looking from the side, check that the protrusion on the roller shaft guide plate is fitted in between two protrusions on the flange end cap.
 - ②: When looking from the rear side of the printer, check that the flange end cap is properly placed on the protrusion on the roller shaft guide plate.

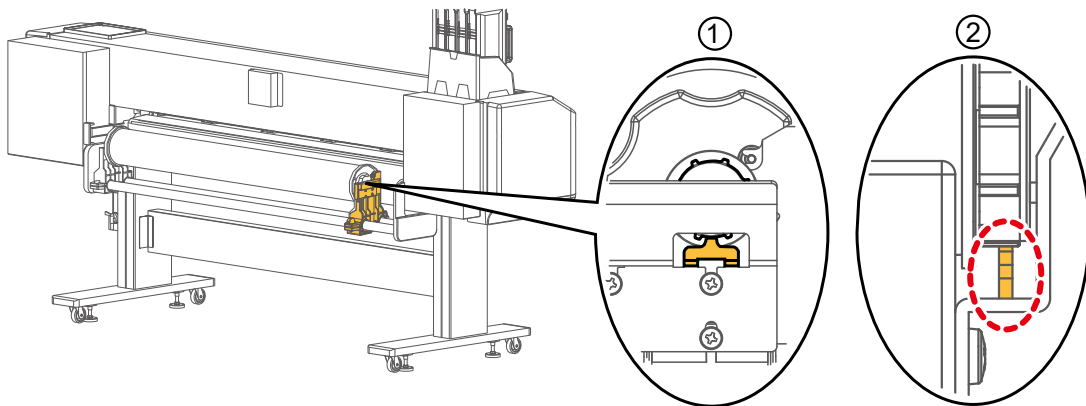

-
- 4** Twist the knob bolt on the right side of the media holder clockwise to tighten.

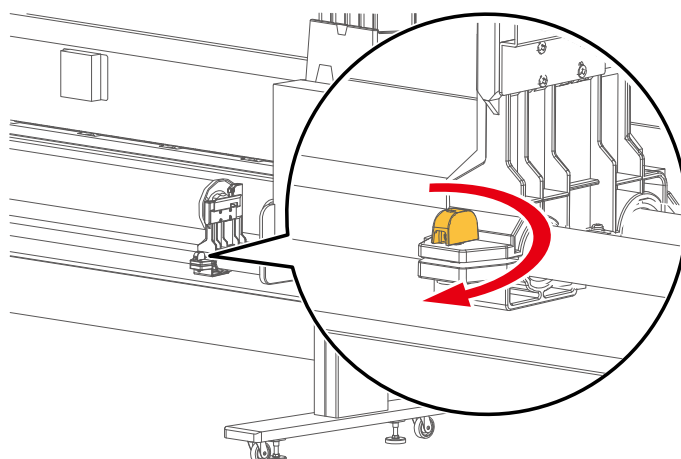

Step4. Load media into the printer

- 1 Check that the printer is powered on.
- 2 Pull the media feed lever to the very front and raise the pressure rollers.

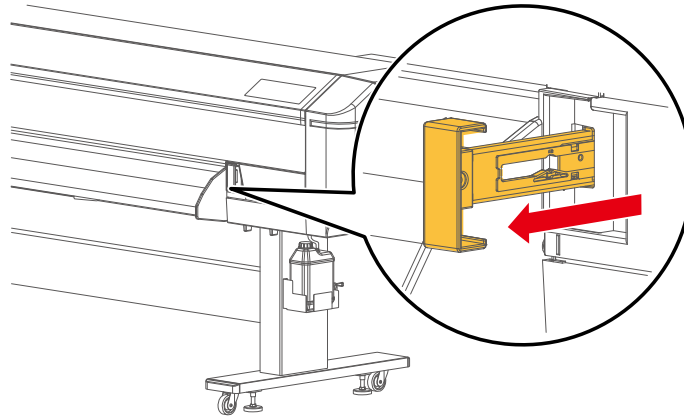

You can also access to the media feed lever from the rear side of the printer.

- Pushing the lever as far as it goes will raise the pressure rollers.

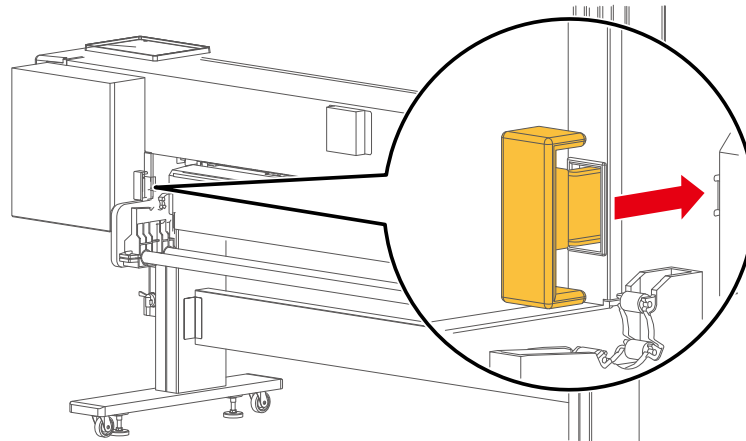

Note

Using the media feed lever, the holddown pressure can be changed between "Normal" and "High".

- From the front side of the printer, pushing the media feed lever as far as it goes will set the holddown pressure to "High" .
- From the rear side of the printer, pulling the media feed lever to the very front will set the pressure to "High" .

→ **"Change pressure that comes onto entire media" P.65**

- 3** Open the front cover.

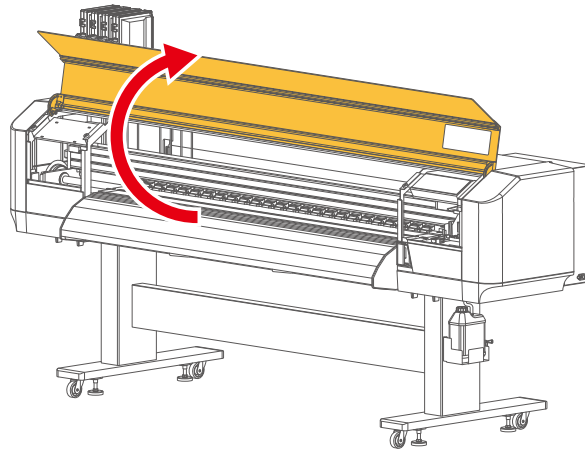

- 4** From the rear side of the printer, insert the leading edge of roll media into the media slot.

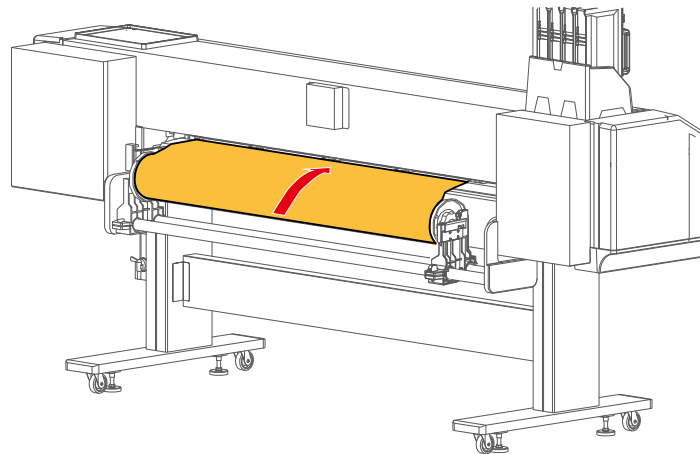

Note

If the end of roll media is loose, wind it again before loading in the printer.

- 5** From the front side of the printer, pull the media for approximately 1 m.

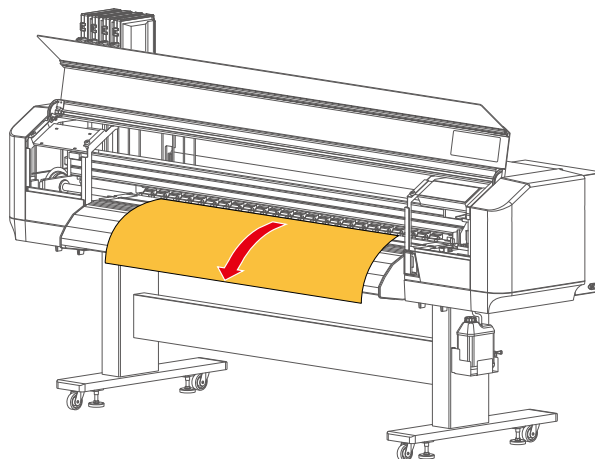

- 6** While one person holds the leading edge of the media, the other person turns the flange to slightly rewind the media onto the roll to remove warp or skew.

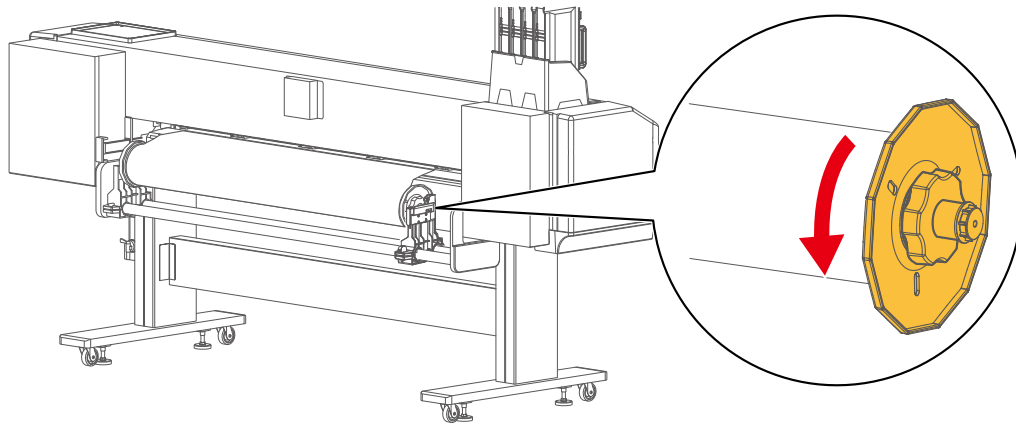

Note

If you release your hands from media while rewinding, it may slip out of the media slot and fall behind the printer.

- 7** Check that the right edge of the media is not positioned to the right of the media guide line.

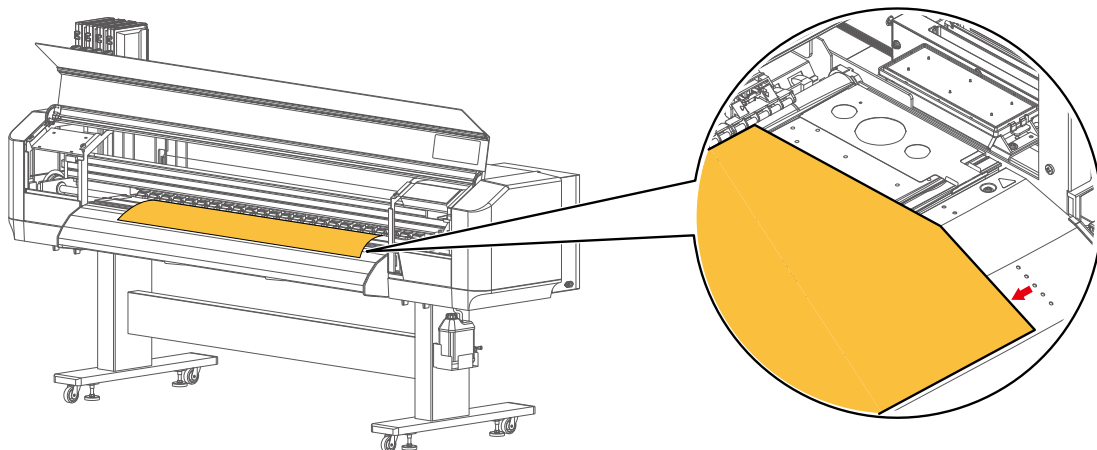

Important!

If not, print quality can be affected.

- 8** If necessary, change the pressure of the pressure rollers individually.

→ **“Change pressure of pressure rollers individually” P.66**

Note

Normally use the default pressure. When printing on thin or soft media, reduce the pressure on the pressure rollers individually.

Step5. After loading the media

- 1 Push the media feed lever to lower the pressure rollers.

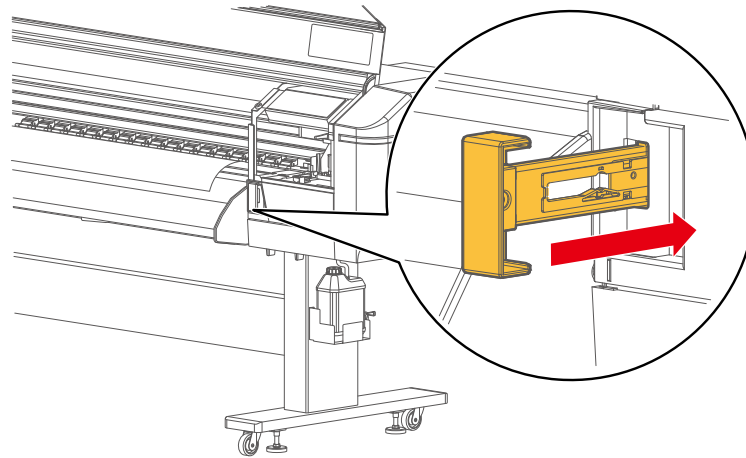

Note

The media feed lever allows you to change the pressure in two ways (Normal / High). For normal use, pull the lever towards you until it clicks to set the pressure to “Normal”.

→ [“Change pressure that comes onto entire media” P.65](#)

- 2 Check that both edges of the media are held down properly by the pressure rollers.

- If it is held like "No good" example, pull the media feed lever towards you as much as possible, then adjust the position of the left or right side of the media holder until the both edges of the media are held down properly. Check on both edges of the media.

→ [“Step3. Placing the media onto the media holder” P.46](#)

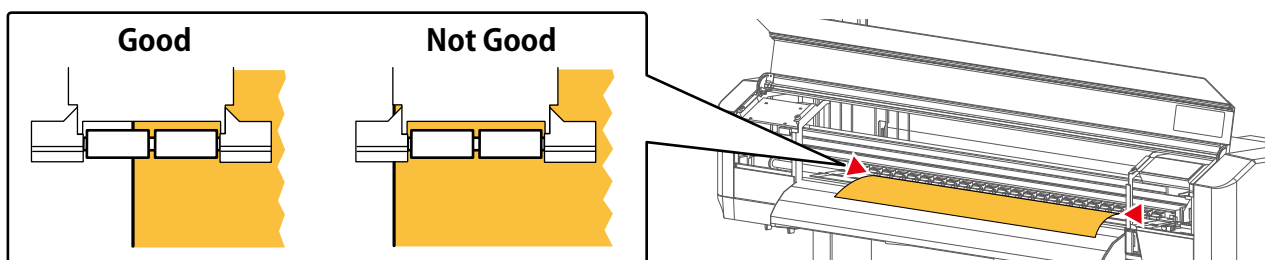

3 Place the edge holders on both edges of the media.

- Lifting the tab at the front of the edge holder will raise the center of the edge holder. Move and place it on the edge of the media while the center of the edge holder is lifted.

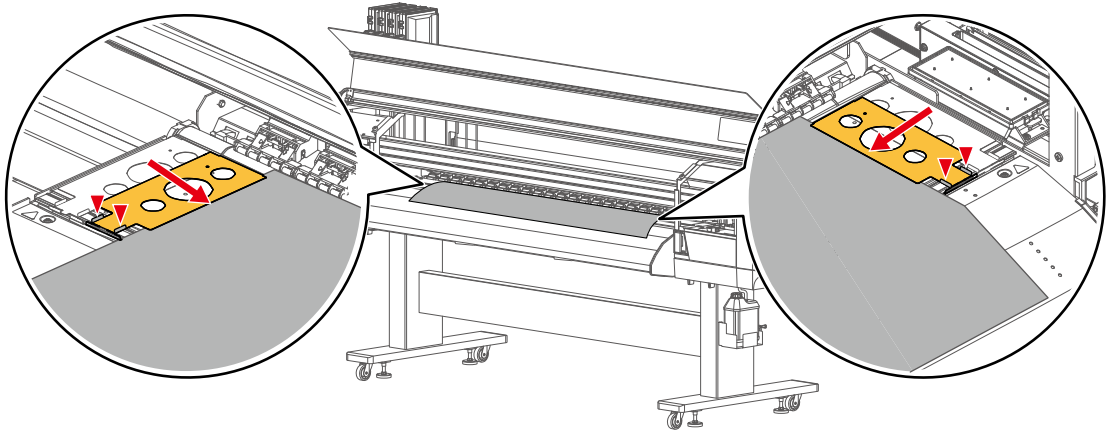

Note

Change the way to use the edge holder depending on the media being used.

→ [“Change the way to use the edge holder depending on the media being used” P.64](#)

Important!

By default, printing starts 6 mm from the edge of the media. When you swapped left and right edge holders, set the side margin to more than 11 mm because ink may stain on the overlapping part of the edge holder and media.

→ [\[Setup\] P.115](#) > [\[Side Margin\] P.118](#)

4 Close the front cover.

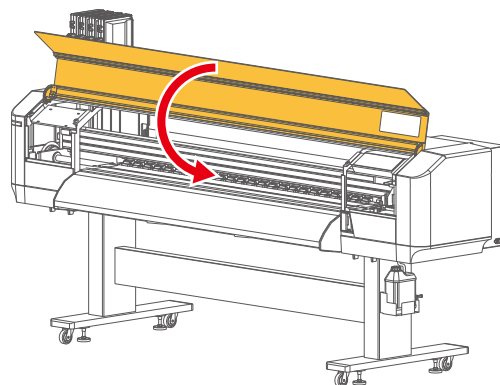

5 Use [▲] / [▼] key to select a media type.



Media: Type ** OK?

- When you loaded the media already registered in the printer: Select the registered media type.
- The printer begins media initialization automatically if not key input is entered for 30 seconds.

Note

The name of media type can be changed from MSM.

→ **MUTOH Status Monitor Operation manual [Edit the name of media type]**

6 Tap [Enter] key so that the media initialization begins. End the media loading.

Nozzle check and head cleaning

Before you start daily printer operation, run a nozzle check. If there are clogged nozzles (missing lines), perform a head cleaning.

Run a nozzle check

Print a nozzle check pattern to check if all nozzles are firing ink properly.

This printer offers the following nozzle check menus:

Nozzle check menus

Nozzle check	Prints a nozzle check pattern using the nozzles selected from “Select Nozzle” in the maintenance menu. → [Maintenance] P.107 > [Select Nozzle] P.108
Nozzle check F	Prints a nozzle check pattern using all nozzles.

1 Load media into the printer.

→ [“Load the media into the printer” P.43](#)

2 Tap [**<**] key while [**Print Ready**] is displayed on the panel.

The following display will appear.



Nozzle check F
Start → Enter

3 Tap [**Enter**] key.

The printer begins printing a nozzle check pattern F.

Note

You can select a nozzle check pattern from the setup menu of the printer control panel.

1. Tap [**Home**] key.
2. Use [**V**] key to select [**Menu3 Test Print**] and tap [**>**] key.
 - [**Test Print 1 Nozzle Check**] appears.
3. Use [**^**] / [**V**] key to select a type of nozzle check and tap [**Enter**] key.
 - The printer begins printing a nozzle check pattern.

4 Check the pattern printed.

- If the nozzle is clogged, go to **“Perform a head cleaning” P.58.**
- If all lines are clearly printed, you can start printing.

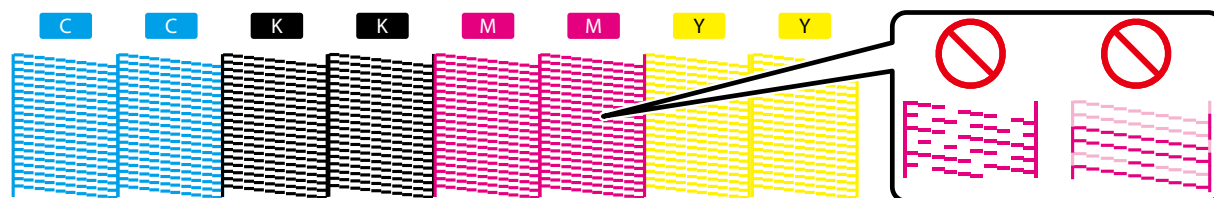

Note

Printer information (print time, serial number, and firmware version) is printed next to the pattern.

Perform a head cleaning

If the nozzle is clogged, perform a head cleaning. The product has several cleaning modes. Use an appropriate mode depending on the nozzle check print result.

Head cleaning mode

Cleaning “Short”	Select this mode if there are clogging on about 10 nozzles. Consumes a small amount of ink.
Cleaning “Normal”	Select this mode if there are clogging on more than 10 nozzles.
Cleaning “Long”	Select this mode if nozzle clogging persists even after Cleaning “Normal” was performed. Consumes more ink than Cleaning “Normal”.

1 Tap [**>**] key while [**Print Ready**] is displayed on the panel.

2 Use [**▲**] / [**▼**] key to select a head cleaning mode and tap [**Enter**] key.



The cleaning cycle begins.



Note

You can also perform a head cleaning from the setup menu of the printer control panel.

1. Tap [**Home**] key.
2. Use [**▼**] key to select [**Menu2 Maintenance**] and tap [**>**] key.
 - [**Maintenance1 Cleaning [Short]**] appears.
3. Use [**▲**] / [**▼**] key to select a head cleaning mode and tap [**Enter**] key.

3 Run a nozzle check print again to see if all nozzles are clear.

→ **“Run a nozzle check” P.56**

- If the nozzle clogging persists, repeat the Cleaning “Normal” two or three times. If nozzle clogging persists even after repeated Cleaning “Normal” attempts, try the Cleaning “Long”.
- If nozzle clogging persists even after Cleaning “Long” attempts two or three times, try other cleaning.

→ **“Nozzle clogging persists even after several head cleaning attempt” P.141**

Calibrating your printer

The following calibration must be performed before you print for the first time or when you change type of media.

- **Calibrate dot placement position in bidirectional printing**

- [“Adjust Print” P.94](#)

- **Correct the media feed amount.**

- [“Media feed adjustment” P.100](#)

Settings depending on media

Change the printer settings depending on the media being used and how it is used.

● If the print head rubs against media and media gets dirty

→ [“Print head height” P.61](#)

● When printing on thin or soft media

→ [“Change the way to use the edge holder depending on the media being used” P.64](#)

→ [“Change pressure that comes onto entire media” P.65](#)

→ [“Change pressure of pressure rollers individually” P.66](#)

Note

When printing on thin or soft media, reducing the vacuum fan can help to prevent wrinkling.

→ [\[Media Type\] P.92](#) > [\[Vacuum Fan\] P.93](#)

Print head height

Normally choose the "Low1" or "Low2" print head height depending on media thickness.

The closer the distance between the media and the print head, the better the consistency of the image quality.

Important!

- Depending on the condition of the media and wrinkling caused by printing conditions, you may get a head strike causing ink smears on the media. In such cases, try followings:
 - Lower the preheater and platen heater temperature settings.
 - [\[Media Type\] P.92](#) > [\[Heater\] P.93](#) > [\[Preheater\] P.93](#) , [\[Platen Heater\] P.93](#)
 - Reduce/cancel the pressure on the individual pressure rollers holding down the area where the wrinkle occurred.
 - [“Change pressure of pressure rollers individually” P.66](#)
- After changing the print head height, make sure to perform an "Adjust Print" calibration.
 - [“Adjust Print” P.94](#)
- While printing, do not open the front cover and change the print head height. Changing the print head height will change the adjustment and print quality cannot be guaranteed.

See the following table for the relationship between print head height and recommended media thickness. Avoid using higher head height unless absolutely necessary, as the wider head gap will cause ink mist to adhere to the nozzles, media, and inside the machine, which may result in poor print quality and damage to printer parts.

Print head height	Recommended media thickness (Up to 1.0 mm)	Maximum media thickness that printer can feed	Description
Low1	Max. 0.3 mm	0.3 mm	Normally use this head height.
Low2	0.3 mm to 0.8 mm	0.8 mm	Use this option for media between 0.3 mm to 0.8 mm thick or when the head strikes occur with Low1 setting.
Middle	0.8 mm to 1.0 mm	1.3 mm	Use this option for media between 0.8 mm to 1.0 mm thick or when the head strikes occur with Low2 setting.
High	-	2.8 mm	Avoid using this option unless a print head strike occurs with Middle setting. Because of wide distance between the print head and media, printing with this setting will generate ink mist and cause the following problems: <ul style="list-style-type: none"> • Nozzle clogging • Ink smudges on media due to ink mist • Ink sticking inside of the printer

Change print head height

1 Open the front cover.

2 Use this lever to change the print head height.

- **High:** The highest print head height setting.
- **Middle:** Use this option for media between 0.8 mm to 1.0 mm thick or when the head strikes occur with Low2 setting.
- **Low2:** Use this option for media between 0.3 mm to 0.8 mm thick or when the head strikes occur with Low1 setting.
- **Low1:** Default print head height. The lowest print head height setting.

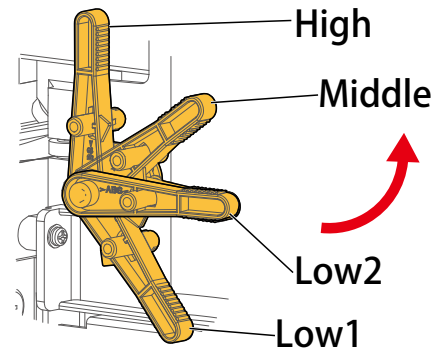

3 Close the front cover.

Important!

There are appropriate combination of print head height and cleaning wiper. When changing the print head height like follows, replace with an appropriate cleaning wiper.

- When changing from “Low1”, “Low2”, “Middle” to “High”
- When changing from “High” to “Low1”, “Low2” or “Middle”

→ **“Replace the cleaning wiper depending on the print head height” P.63**

4 Perform an “Adjust Print” calibration.

→ **“Adjust Print” P.94**

Replace the cleaning wiper depending on the print head height

Important!

- This printer has two types of cleaning wipers (black / gray).
- There are appropriate combination of print head height and cleaning wiper (See below). Proper cleaning cannot be carried out with incorrect combination. When changing the print head height, check the combination and replace with an appropriate cleaning wiper if needed.
- In the factory default, the black cleaning wiper is installed.

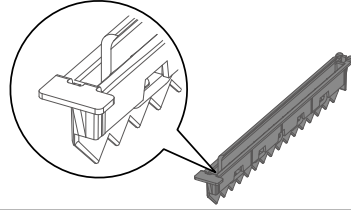
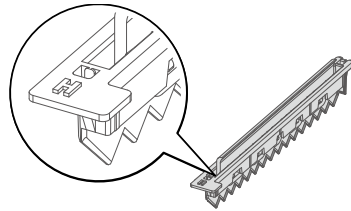
Print head height	Types of cleaning wiper
For “Low1”, “Low2”, “Middle”	Black (installed in the printer when shipped) 
For “High”	Gray (bundled in the printer box) 

For replacement procedure, see [“Replace the Cleaning Wiper” P.158](#).

Change the way to use the edge holder depending on the media being used

Edge holder can be installed in different ways depending on the media being used. To change, remove the edge holders from the platen, swap the left and right sides and reinstall them.

- Installation method for typical roll media

The hole on the top of edge holder is positioned on the outer side. This will hold down roll media lightly.



- Installation method for thin or soft media

Swap left and right edge holders and attach them as shown in the illustration. The hole on the top of edge holder is positioned on the inward. This will hold down wider area on roll media.



1 Open the front cover.

2 Slide both edge holders to the maintenance cover L side along the platen.

Remove the edge holders from the end of the platen on the maintenance cover L side.

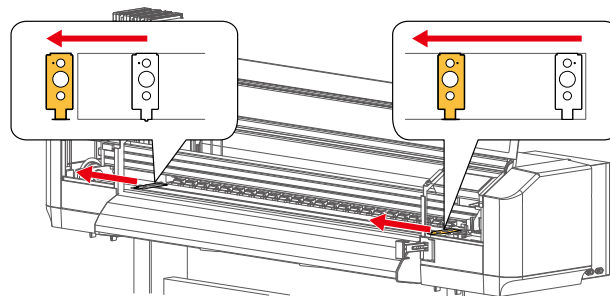

3 Swap left and right edge holders and attach them to the platen.

Insert the edge holders from the maintenance cover L side and fit them to the groove on the platen to attach.

Important!

By default, printing starts 6 mm from the edge of the media. When you swapped left and right edge holders, set the side margin to more than 11 mm because ink may stain on the overlapping part of the edge holder and media.

→ [\[Setup\] P.115](#) > [\[Side Margin\] P.118](#)

Change pressure that comes onto entire media

To change the holddown pressure applied across the entire width of media, use the media feed lever. The media feed lever allows you to change the pressure in two ways (Normal / High).

- **Normal:** Recommended for typical roll media. Push the lever from the front side of the printer until it clicks.
- **High:** Use this when you want to apply strong pressure to print on heavy weight media (such as Tarpaulin). To apply "High" pressure, push the lever as far as it goes.

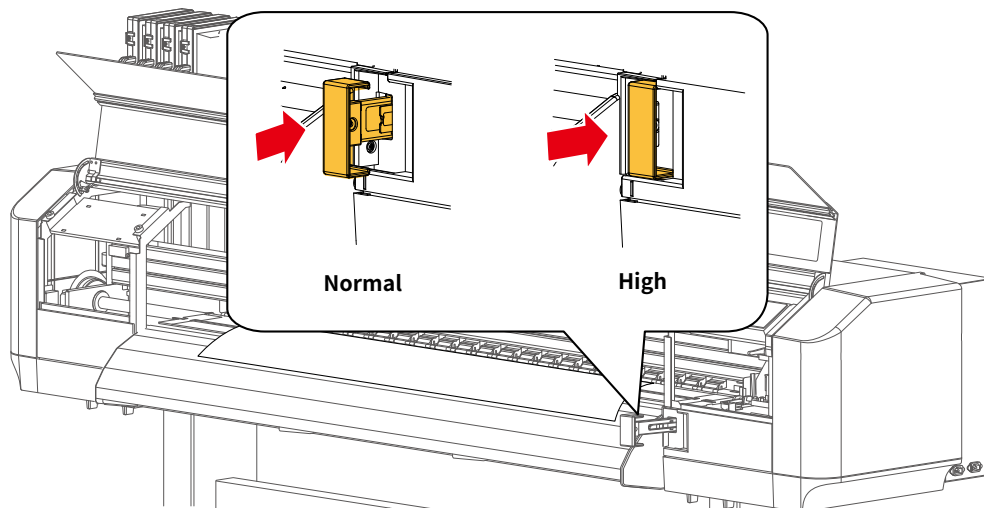

Important!

Every time after you change the holddown pressure by individual slide lock lever, you must perform a "PF Adjust" calibration.

→ **"Media feed adjustment" P.100**

Change pressure of pressure rollers individually

When printing on thin or soft media, sometimes the media hits the print head causing ink smudge on the media. In such cases, reducing or disabling pressure individually may help.

To change pressure of pressure rollers individually, use the slide lock lever.

The slide lock lever on each pressure roller can be used to change the pressure in three ways (“Normal”, “Low, or “Cancel”).

- **Normal:** Recommended for typical roll media. This is the factory default setting.
- **Low:** Less pressure than “Normal”.
- **Cancel:** The pressure rollers that were set to “Cancel” by the slide lock lever remain in UP position even if the media feed lever is pushed in.

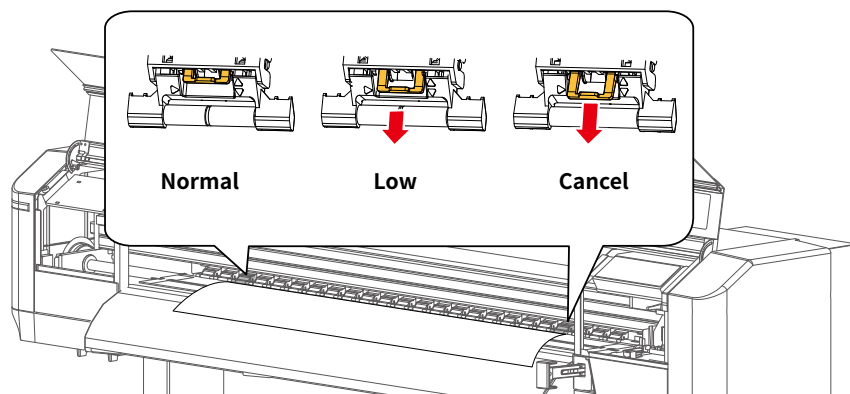

Important!

Every time after you change the holddown pressure by individual slide lock lever, you must perform a “PF Adjust” calibration.

→ [“Media feed adjustment” P.100](#)

Note

- Thin or soft media has tendency to wrinkle easily during printing. The wrinkles can contact the bottom side of the print head causing ink smudge on the media. Canceling the pressure rollers on both edges of media will help to prevent wrinkling.
- First, try with the pressure rollers holding both ends of the media to see if it improves. If the problem persists, reduce or cancel more rollers.

- 1 Open the front cover.
- 2 Change the position of the media feed lever and the slide lock lever depending on the use.
To change the position of the slide lock lever, push the lever down then change the position.
 - [“To set the slide lock lever to “Normal”” P.67](#)
 - [“To set the slide lock lever to “Low”” P.68](#)
 - [“To set the slide lock lever to “Cancel”” P.69](#)
- 3 Close the front cover.

-
- 4** Perform a “PF Adjust” calibration
 → “Media feed adjustment” P.100
-

To set the slide lock lever to “Normal”

Important!

Changing the slide lock lever to “Normal” or “Low” while the media feed lever is fully pulled towards you (pressure rollers are in up position) can cause malfunction. Follow these operation procedure to change the pressure.

-
- 1** Set the media feed lever to the “Normal” position.
 → “Change pressure that comes onto entire media” P.65

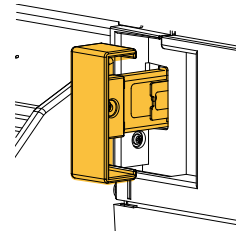

-
- 2** Set the slide lock lever to “Normal”.
- Push the lever all the way in.

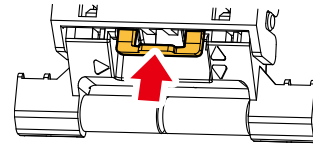

Note

If you want to change the pressure that comes onto entire media to "High", change the pressure using the slide lock lever and then push the media feed lever all the way in.

→ “Change pressure that comes onto entire media” P.65

To set the slide lock lever to “Low”

Important!

Changing the slide lock lever to “Normal” or “Low” while the media feed lever is fully pulled towards you (pressure rollers are in up position) can cause malfunction. Follow these operation procedure to change the pressure.

- 1 Set the media feed lever to the “Normal” position.

→ “Change pressure that comes onto entire media” P.65

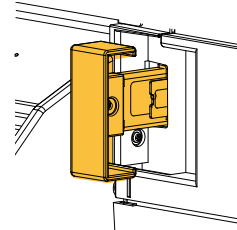

- 2 Set the slide lock lever to “Low”.

Pull the lever towards the front until it clicks into place.

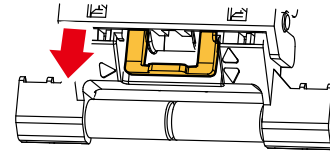

Note

If you want to change the pressure that comes onto entire media to "High", change the pressure using the slide lock lever and then push the media feed lever all the way in.

→ “Change pressure that comes onto entire media” P.65

To set the slide lock lever to “Cancel”

Important!

Changing the slide lock lever to “Cancel” while the media feed lever is set to “Normal” or “High” (pressure rollers are in down position) can cause malfunction. Follow these operation procedure to change the pressure.

- 1 Pull the media feed lever to the very front and raise the pressure rollers.

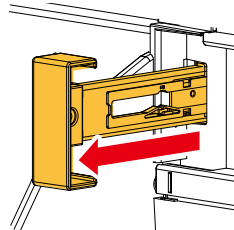

- 2 Set the slide lock lever to “Cancel”.
 - Pull the lever to the very front.

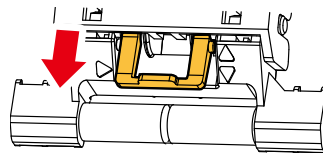

- 3 Push the media feed lever to lower the pressure rollers.

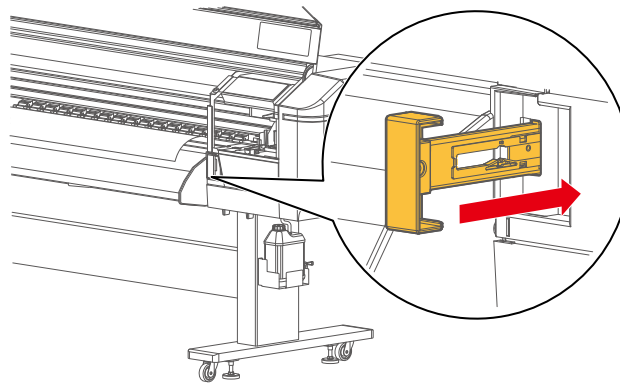

Note

The media feed lever allows you to change the pressure in two ways (Normal / High). For normal use, pull the lever towards you until it clicks to set the pressure to “Normal”.

→ **“Change pressure that comes onto entire media” P.65**

Restrictions on slide lock lever

When the media feed lever is set to “High”, the pressure that can be adjusted with the slide lock lever is limited to “Normal” or “Cancel”. Even when set to “Low”, the holddown pressure cannot be reduced.

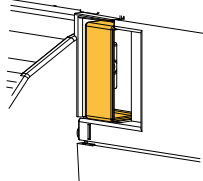
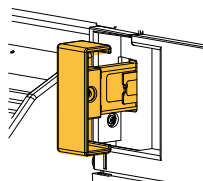
Media feed lever	Slide lock lever
<p>High</p> 	<p>Normal / Cancel</p>
<p>Normal</p> 	<p>Normal / Low / Cancel</p>

Important!

Changing the slide lock lever to “Normal” or “Low” while the media feed lever is fully pulled towards you (pressure rollers are in up position) can cause malfunction.

Start printing

Here we will explain basic printing procedure using MUTOH RIP software “VerteLith”.
For more details of VerteLith setup and operation, see the “VerteLith user manual”.

Print an image

- 1 Start VerteLith. Select “XPJ-1641SR-P2” from the list of printer (①).
 - “XPJ-1641SR-P2” appear (②).

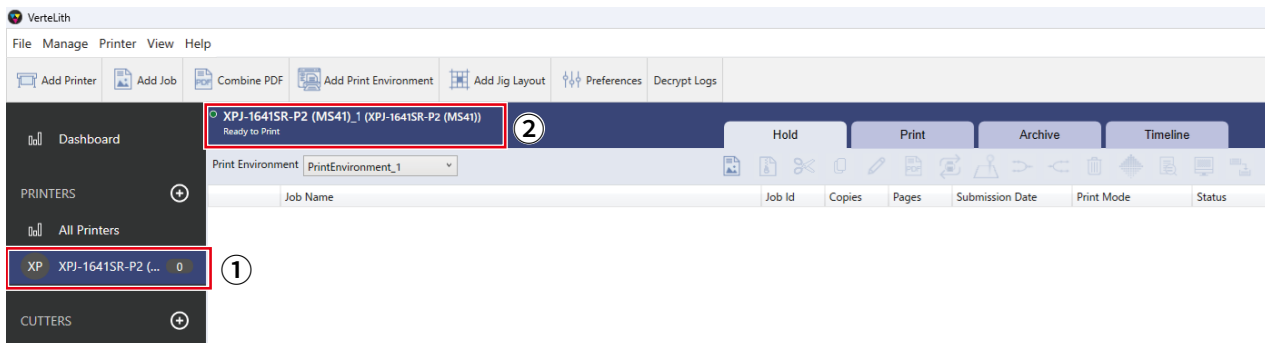

Note

For how to add a printer to VerteLith, see the “VerteLith user manual”.

- 2 Add an image file you want to print.
 - In the Hold queue, click the **[Add Job]** icon (③) so that the open dialog appears.

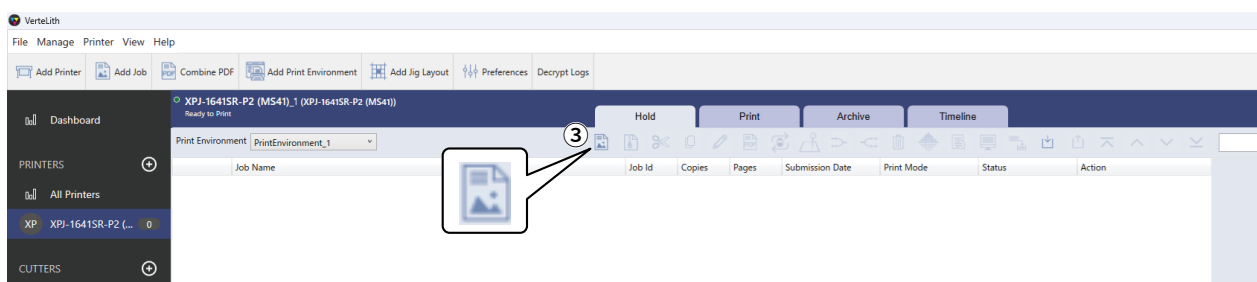

- Select an image file and click **[OK]** to add it to the Hold queue (④). You can add multiple files here.

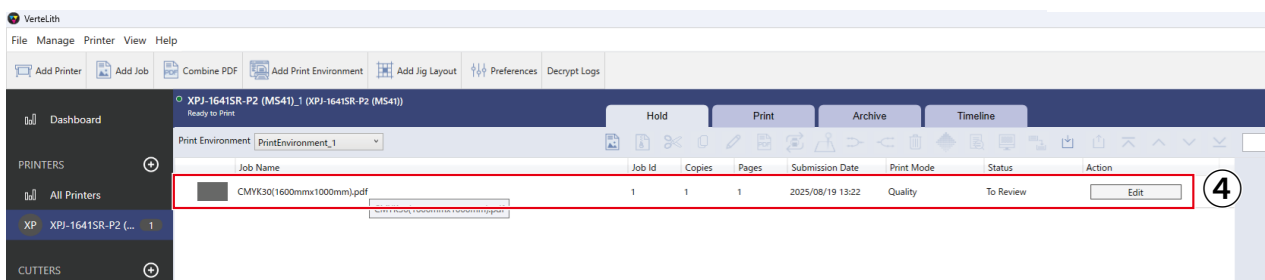

Note

You can also drag and drop files in the Hold queue.

3 Select a print job and click **[Edit]**(⑤) or **[Edit Job]**(⑥).

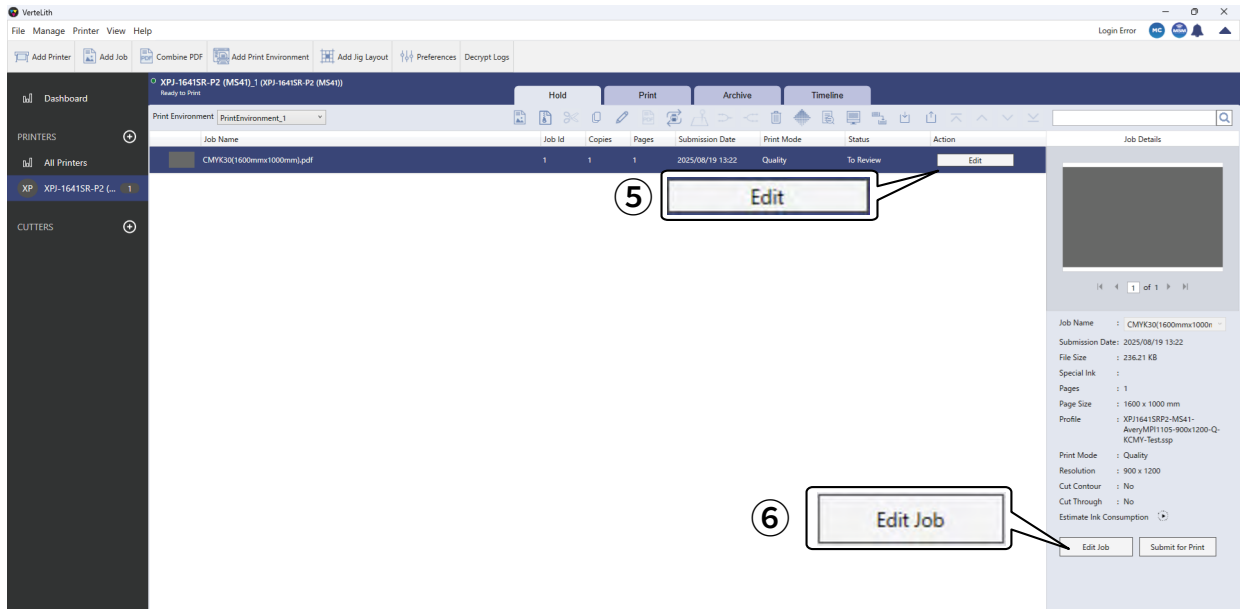

4 **[Edit Job Settings]** (⑦) appears. Click the **Printer Profile** tab (⑧).



5 Configure the basic print settings.

- Profile Group option (9)
 - Select an appropriate one depending on the ink being used.
- Profile option (10)
 - Select an appropriate profile depending on the media type and print mode.
- Printer Options (11)
 - Additional advanced settings can be configured (you can also print with default settings).

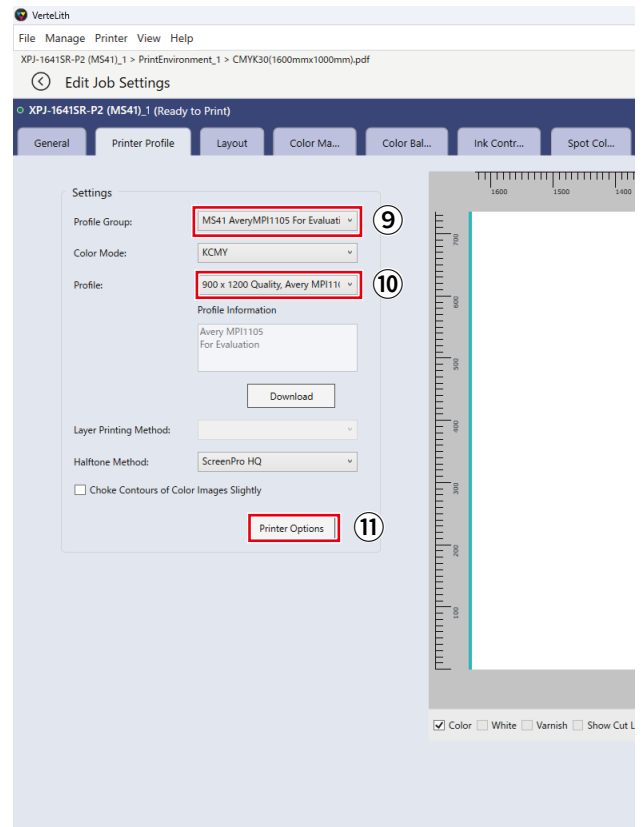

6 Click [**Submit for Print**] (12).

- The job will move to the Print queue. Printing begins after RIP processing.

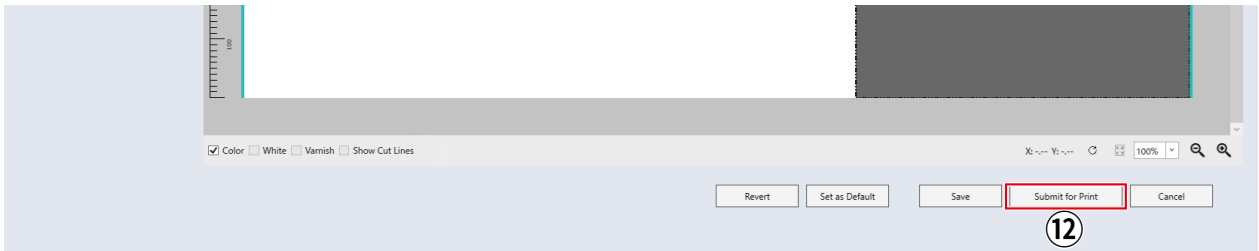

- The processing status of the job (Sending, Waiting for ripping, Ripping, Waiting for Print) can be viewed (13).

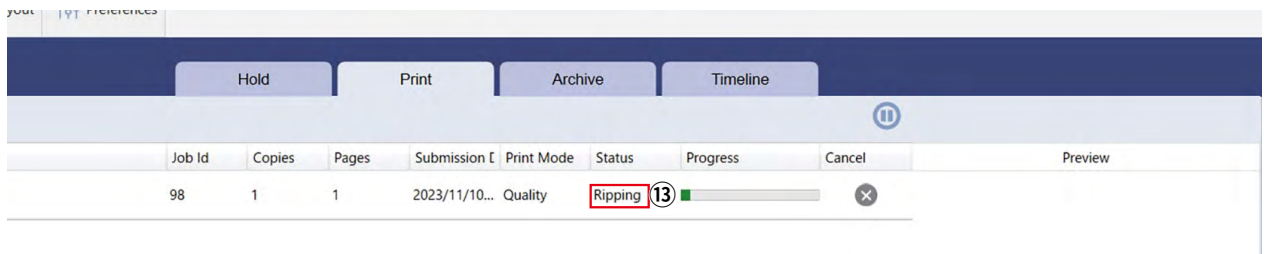

- The job will automatically move to the Hold queue after printing (14).

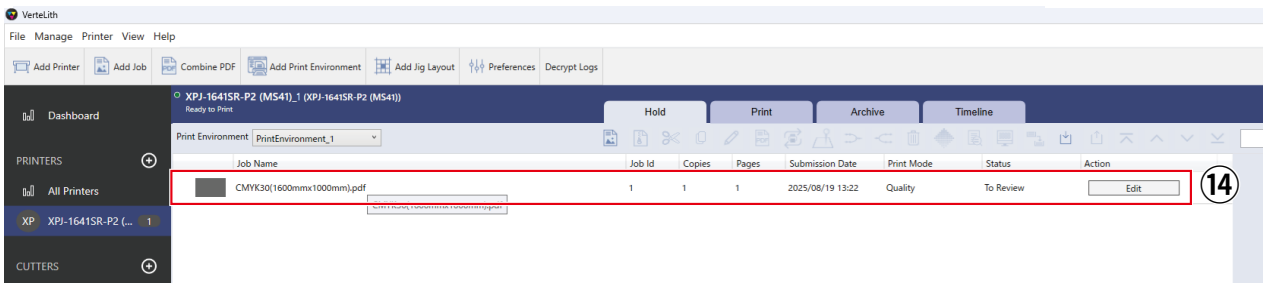

Pause / Resume / Cancel a print job

- 1 Clicking the **[Pause Print]** icon (①) will put the RIP processed job into “Waiting for Print” status (you cannot pause the job being sent).

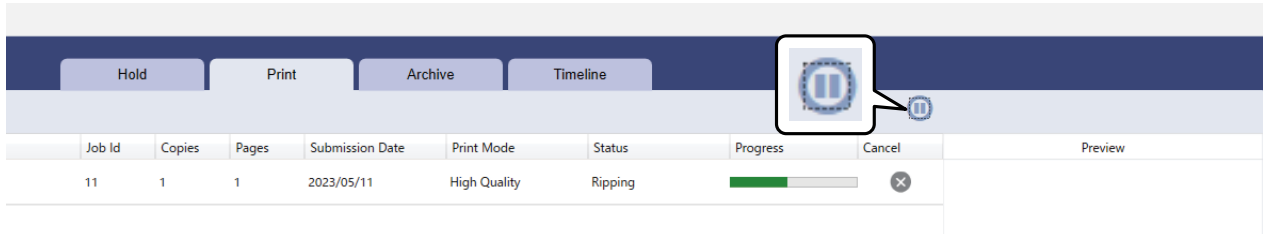

- 2 Clicking the **[Resume Print]** icon (②) will resume the print job which is in “Wait for Print” status.

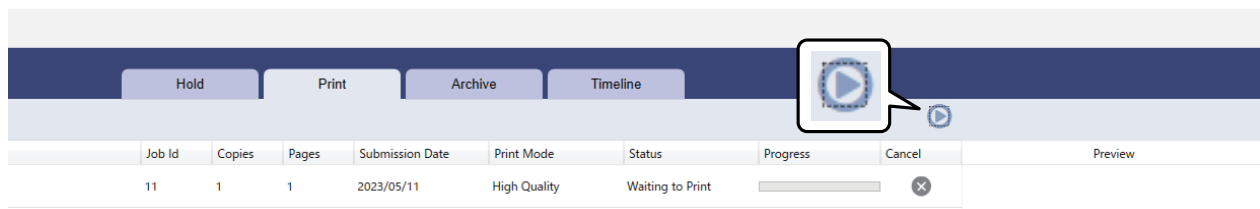

- 3 Clicking the **[Cancel]** icon (③) will cancel printing the job.

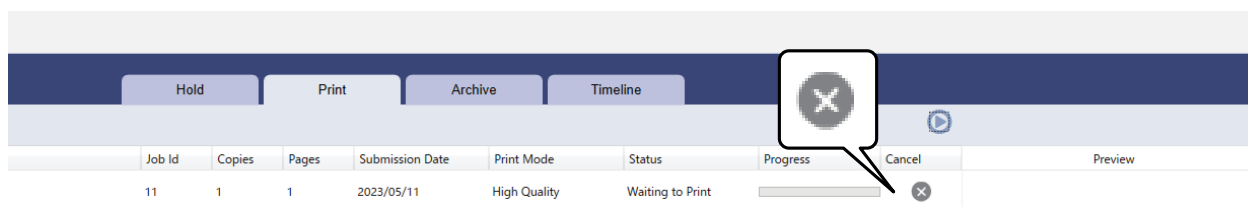

Operating from the printer control panel

Feeding media

- 1 Check that the pressure rollers are in down position.

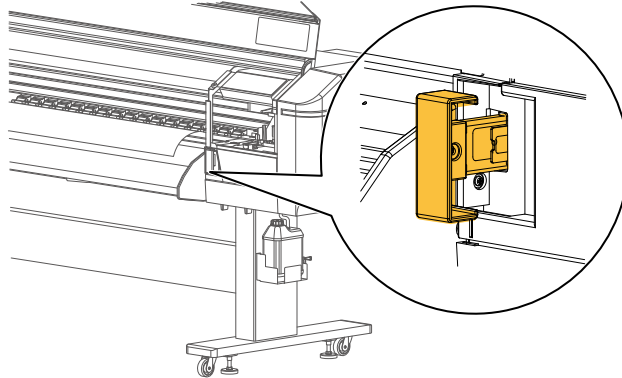

- 2 Tap [▲] or [▼] key.

- [▲] key: Feed the media backward.
- [▼] key: Feed the media forward.

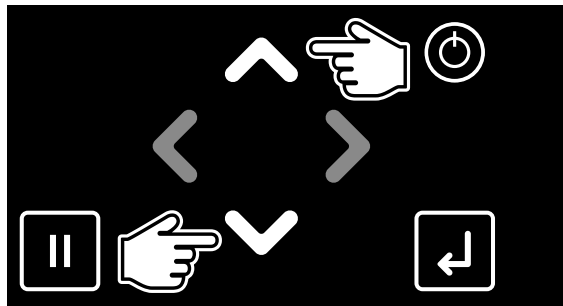

Note

Long tap the key to feed media with high speed.

- 3 Once the media has reached the intended position, release the key.

Pause / Resume printing

- 1 Tap [**Cancel**] key while printing.

Printing pauses.



Note

This operation does not delete the print data sent to the printer. To cancel and delete the data, see the following section.

→ [“Cancel printing” P.78](#)

- 2 Tap [**Cancel**] key again to resume printing.

Pausing Print
Cancel Print → Enter

Important!

Print quality cannot be guaranteed if printing is paused.

Cancel printing

1 Tap **[Cancel]** key while printing.

Printing pauses.

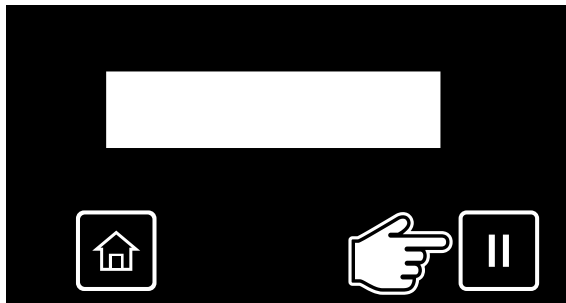

Note

Tapping **[Cancel]** key again will resume printing.

2 Tap **[Enter]** key to cancel printing.

- Once canceled, you cannot resume the job.
- The data sent to the printer will be deleted.

Pausing Print
Cancel Print -> Enter

Important!

You can also cancel printing from the remote panel on MSM.

Start printing during warm-up

Caution

-  Do not touch the media guide while printing or when the message **[Warming Up]** appears on the panel. There is a risk of burns.

- 1 Check that the printer is warming up.

Warming Up

- 2 Send a print data.

- a. **[Skip Heater Warm Up? No]** appears.
- b. Selecting **[Yes]** and tapping **[Enter]** key will begin printing.

Skip Heater Warm Up?

Yes

Important!

Print quality cannot be guaranteed if printing is started during warm-up.

Note

Even if printing is started during warm-up, the heater warms up to the specified temperature.

Cutting Media

- 1 Check that printing has been finished, and then tap **[Cancel]** key.



- 2 Tap **[Enter]** key.



The printer will advance the media for the bottom margin and will cut it off the roll media.

Note

- If the leading edge of a new roll media is not straight, cut it before printing.
- The printer is unable to cut media automatically if the “Media Initial” menu is set to **[Off]**.
→ [\[Setup\] P.115](#) > [\[Media Initial\] P.115](#)
- Setting the “Output Mode” menu to **[Auto Cut]** will automatically cut media after printing.
→ [\[Setup\] P.115](#) > [\[Output Mode\] P.115](#)
- The cutter blade is consumable parts. Replace regularly.
→ [“Replace the Cutter” P.155](#)

Menus you can access while printing





- 1 While one of these messages appears, tap **[Home]** key.



Receiving
PG: Low1 W: 1625 mm

Converting
PG: Low1 W: 1625 mm

Printing
PG: Low1 W: 1625 mm

- 2 Select a menu and tap **[>]** key.

Menu	Functions
Temperature	<p>Heater temperature while printing can be checked. The current temperature and the specified temperature are displayed in [].</p> <ul style="list-style-type: none"> • [▲] / [▼] key: Select the item you want to view. <div style="border: 1px solid green; padding: 5px;"> <p> Note</p> <ul style="list-style-type: none"> • The temperatures displayed are for reference only. Exact accuracy is not guaranteed. • The current temperature blinks constantly regardless of whether the warm-up is completed or not. </div>
Heater	<p>Settings of each heater can be changed.</p> <ul style="list-style-type: none"> • [▲] / [▼] key: Change the setting. • [Enter] key: Apply the change. <div style="border: 1px solid green; padding: 5px;"> <p> Note</p> <ul style="list-style-type: none"> • The change made will become invalid after printing. • The change made can be saved in the selected media type. <p>→ [Backup] P.82</p> </div> <div style="border: 1px solid orange; padding: 5px; margin-top: 10px;"> <p> Caution</p> <p> Do not touch the media guide while printing or when the message [Warming Up] appears on the panel. There is a risk of burns.</p> </div>

Menu	Functions
<p>PF Adjustment</p>	<p>This adjustment corrects the media feed amount.</p> <ul style="list-style-type: none"> • [▲] / [▼] key: Change the setting. • [Enter] key: Apply the change. <div style="border: 1px solid #90EE90; padding: 5px;"> <p> Note</p> <ul style="list-style-type: none"> • The change made will become invalid after printing. • The change made can be saved in the selected media type. <p>→ [Backup] P.82</p> </div>
<p>Backup</p>	<p>Save the change made in the following menus to the selected media type.</p> <ul style="list-style-type: none"> • Preheater • Platen Heater • Dryer • PF Micro Adjust <p>Select [Update Parameter? Yes] and tap [Enter] key.</p>
<p>Job Status</p>	<p>Displays information about a print job being printed.</p> <ul style="list-style-type: none"> • [▲] / [▼] key: Select the item you want to view. <div style="border: 1px solid #90EE90; padding: 5px;"> <p> Note</p> <ul style="list-style-type: none"> • The values displayed are for reference only. Exact accuracy is not guaranteed. • If print data does not contain length information, "0" will be displayed in all items. </div>
<p>MPS</p>	<p>Displays the status of the MPS function. MPS function settings can be changed from MSM.</p>

Checking ink level and replacing ink bag

Checking ink level

1 Tap [**Home**] key.

2 Access the “Ink Status” menu.

Menu flow



- [**▲**] / [**▼**] key: Select a menu item.
- [**>**] key: Enter the menu.

3 Tap [**Enter**] key.

The ink level is displayed in percentage (0 % to 100 %).

KCMY : 100/ 90/ 90/ 80/

K: Black, C: Cyan, M: Magenta, Y: Yellow

→ “When an ink bag is nearing replacement” P.84

Note

- See “**Ink slots**” P.26 for information on ink color and corresponding ink slot.
- To display various information on ink, use genuine ink and smart chip cards. Ink status will not be displayed correctly if non-genuine products are used.
- If the ink level is blinking at 10 %, smart chip recovery is being performed for the corresponding ink bag.

→ “**Smartchip Recovery**” P.179

When an ink bag is nearing replacement

When the ink level is low, the status light on the printer control panel blinks with beep sound.

1 Tap **[Enter]** key.

- The beep sound stops.
- In this figure, the yellow ink is nearing replacement.

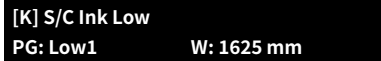

[K] S/C Ink Low
PG: Low1 W: 1625 mm

2 Replace with a new ink bag.

→ [“Replacing ink bag” P.85](#)

Replacing ink bag

When an ink bag runs out of ink, the status light on the printer control panel turns on red with beep sound.

[Ink End] or **[S/C Ink End]** will be displayed. Replace ink quickly.

If ink is not replaced within a certain period, printing will pause. In such case, replacing with a new ink bag will resume printing.

Important!

- When the printer is powered off, do not replace with a new ink bag. The printer may not be able to detect ink level correctly.
- When moving an ink bag from cold to warm place, rest it in room temperature for at least 3 hours before use.
- If you do not have a new ink bag for replacement, leave the old one installed. Leaving the printer without ink bags installed could cause nozzle clogging.

! Make sure to read the following sections before this task.

- **“Product handling” P.12**
- **“Ink and waste fluid” P.17**

Removing the ink bag case

1 Wear protective equipment.

- **“Wearing protective equipment” P.130**

2 Tap [Enter] key.

- The beep sound stops. The buzzer beeps again if ink is not replaced even after a while.
- In this figure, the yellow ink needs replacement.

[Y] Ink End

3 Replace with a new ink bag.

Remove the ink bag case of the ink bag to be replaced and the corresponding smartchip card.

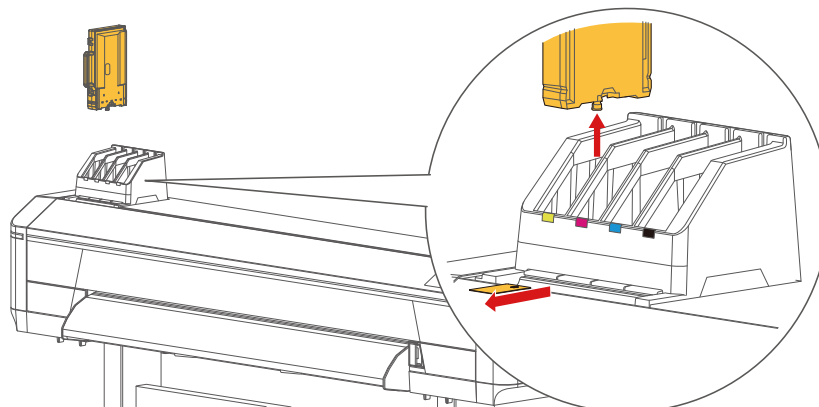

4 Unlock four latches and open the ink bag case.

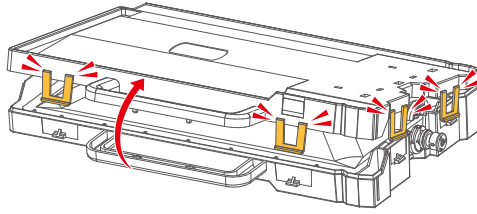

Important!

Do not apply excessive force when unlocking the latch. This will cause damage to the latch.

5 Remove the empty ink bag.

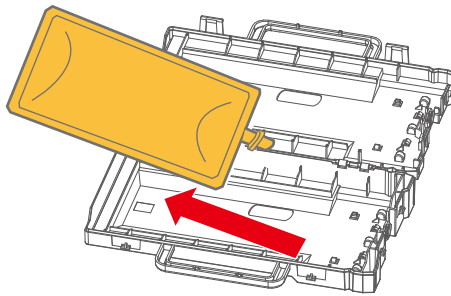

Note

Put the empty ink bag in a plastic bag and dispose of it according to the local regulations.

Loading a new ink bag

1 Prepare a new ink bag and follow the instructions below to agitate ink in the ink bag.

- a. Hold the ink bag with the ink outlet facing up and wait for three seconds.
- b. Invert it with the ink outlet facing down and wait for three seconds.
- c. Repeat this 3 times.

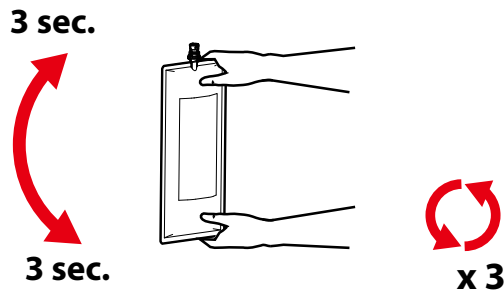

- 2 Place the ink bag in the ink bag case.

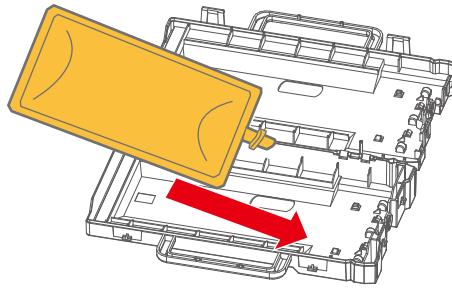

- 3 Close the ink bag case.

- a. Make sure that the spout of the ink bag is properly fitted into the groove in the case.

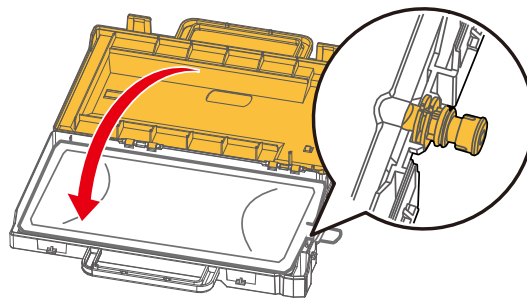

Important!

If not fitted, the printer cannot correctly detect the ink bag.

- b. Close the latches (x4) of the ink bag case properly.

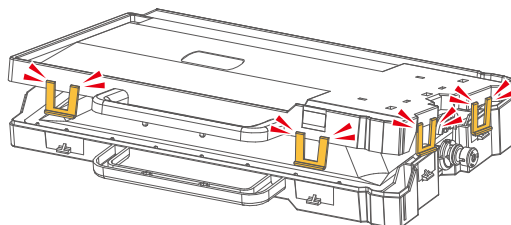

Important!

If not closed properly, it may cause ink leakage.

4 Insert the ink bag case and smartchip card into each slot.

- a. Make sure to match the colored label on the ink slot and the colored label on the ink bag.
- b. Face the latch side towards the front and insert the case into the slot.
- c. Make sure that they are fully inserted.

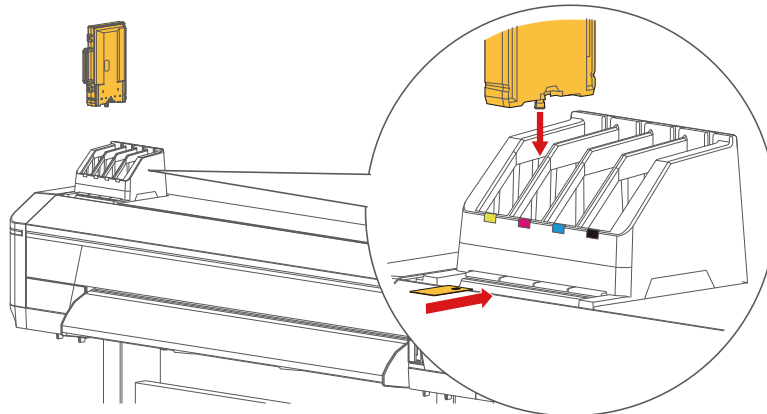
**Important!**

Ink leakage may occur if not fully inserted.

3 Various settings

Panel setup menu	90
Menu1: Media Type	92
Menu2: Maintenance	107
Menu3: Test Print	112
Menu4: Setup menus	115
Menu5: Roll Length Manage	122
Menu6: Printer Info.	125

Panel setup menu

You will configure the various settings using the setup menu in the printer control panel.

How to operate the menu

1 Tap [Home] key.

The setup menu appears in the printer control panel.



Note

You cannot enter the setup menu while printing or receiving data (while the power button is blinking).

2 To select a menu item

Tapping [▲] or [▼] key will scroll through the menu.

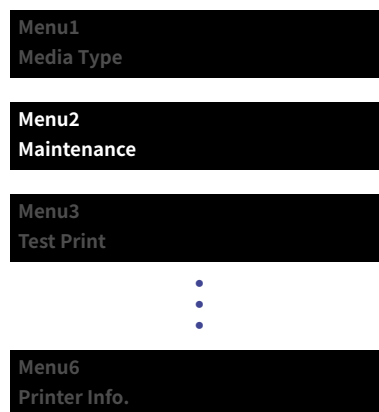

3 To go to the selected menu

Tap [**>**] key.

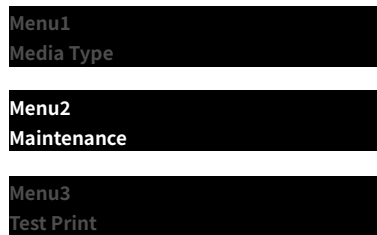

4 To return to the upper level menu

Tap [**<**] key. In this example, the display returns to [**Menu2 Maintenance**].

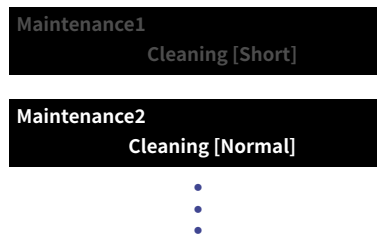

5 To choose the setting item or enter the value

Tapping [**▲**] or [**▼**] key will scroll through the item or increase or decrease a value.

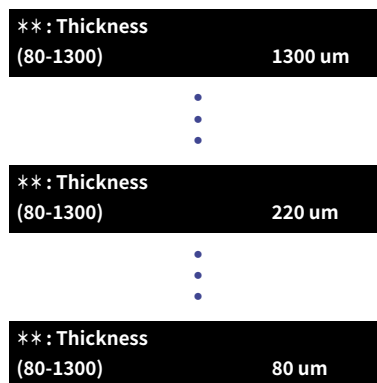

6 To confirm the setting or run the selected function

Tap [**Enter**] key.

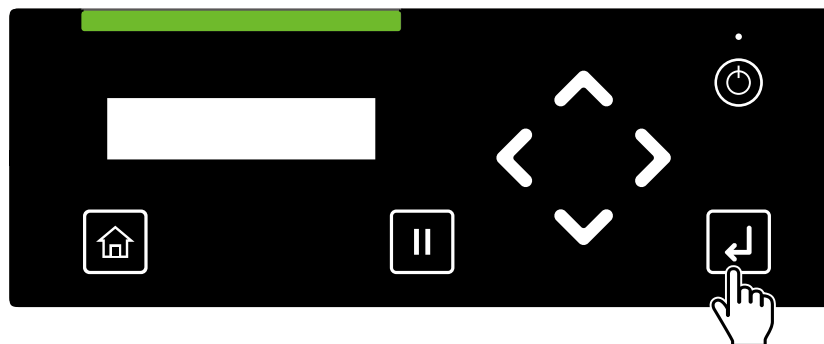

Menu1: Media Type

Menu List

- Underlines in the setting range indicate the default settings.

	Setting range/ Submenu	Functions	→
Media Type		Create your own media preset for each media type and save it with appropriate printer settings. You can create up to 15 types.	
Type1 to Type15			
Adjust Print		Calibrate dot placement position in bidirectional printing. Enter the thickness of media before adjustment.	
Auto	ALL, Standard, Adjust Pattern A, C, D	The color sensor reads the adjustment pattern print and the printer runs automatic “Adjust Print” calibration. <ul style="list-style-type: none"> • ALL: Automatically runs calibration of all adjustment patterns. • Standard: Automatically runs the same calibration as [Standard]. • Adjust Pattern A, C, D: Automatically runs calibration of the selected adjustment pattern. 	
Standard	Confirm Pattern, Rough Pattern, Fine Pattern	Print an adjustment pattern and enter the number of the pattern that has the least misalignment. This option calibrates the print mode specified in the selected media type. <ul style="list-style-type: none"> • Confirm pattern: Print a test pattern for Adjust Print. • Rough pattern: Perform this when misalignment is large. Print the adjustment pattern and enter the number of the pattern that has the least misalignment. • Fine pattern: Perform this when misalignment is small. Print the adjustment pattern and enter the number of the pattern that has the least misalignment. 	P.94
Custom	Confirm Pattern, Rough Pattern ALL, Rough Pattern A, C, D, Fine Pattern ALL, Fine Pattern A, C, D	Print an adjustment pattern and enter the number of the pattern that has the least misalignment. This option calibrates all print modes. <ul style="list-style-type: none"> • Confirm pattern: Print a test pattern for Adjust Print. • Rough Pattern ALL: Print all the rough adjustment patterns and enter an adjustment value for each pattern. • Rough pattern A, C, D: Print the selected rough adjustment pattern and enter an adjustment value. • Fine Pattern ALL: Print all the fine adjustment patterns and enter an adjustment value for each pattern. • Fine Pattern A, C, D: Print the selected fine adjustment pattern and enter the adjustment value. 	

		Setting range/ Submenu	Functions	→										
	PF Adjust		This adjustment corrects the media feed amount.	P.100										
	Auto		The color sensor reads the adjustment pattern print and the printer runs automatic “PF Adjust” calibration.											
	Print	11 patterns of 0%, ± 0.1 %, ± 0.2%, ± 0.5%, ± 0.8%, ± 1.2 %	This menu prints an adjustment pattern.											
	Adjustment	- 5.00 to <u>0.00</u> to 5.00 %	Check the adjustment pattern and enter an optimal adjustment value.											
	Adjust Distance		Correct this when misalignment is seen in the printed drawing or dimensions.											
	Print	100 to <u>250</u> to 500 mm	Print an adjustment pattern with specified length.											
	Adjustment	Default length ± 50.0 mm	Measure the printed pattern and enter the measured length.											
	Confirm Print	100 to <u>250</u> to 500 mm	Print a confirmation pattern for verification.											
	Heater		Set the optimum heater temperature to reduce ink bleeding and dry ink quickly.											
	Preheater	Off, <u>30</u> to 50 °C	Preheat media to avoid rapid temperature changes.											
	Platen Heater	Off, <u>30</u> to 50 °C	Prevent ink bleeding in the print.											
	Dryer	Off, <u>30</u> to 50 °C	Dry ink after printing.											
	Vacuum Fan	Off, Low, Medium, High, <u>Ex High</u>	Select the suction power level to hold down media. For soft media, reduce suction power.											
	Print Mode	Ex High Quality, High Quality, <u>Quality</u> , Production, Banner, Draft, Super Draft	<table border="1"> <thead> <tr> <th>Print Mode</th> <th>Quality</th> <th>Speed</th> </tr> </thead> <tbody> <tr> <td>Ex High Quality</td> <td rowspan="6">↑ High Low ↓</td> <td rowspan="6">↑ Slow Fast ↓</td> </tr> <tr> <td>High Quality</td> </tr> <tr> <td>Quality</td> </tr> <tr> <td>Production</td> </tr> <tr> <td>Banner</td> </tr> <tr> <td>Draft</td> </tr> <tr> <td>Super Draft</td> </tr> </tbody> </table>		Print Mode	Quality	Speed	Ex High Quality	↑ High Low ↓	↑ Slow Fast ↓	High Quality	Quality	Production	Banner
Print Mode	Quality	Speed												
Ex High Quality	↑ High Low ↓	↑ Slow Fast ↓												
High Quality														
Quality														
Production														
Banner														
Draft														
Super Draft														
Effect	None, i-ScreenFine	An appropriate effect option for the print mode is selected automatically. <ul style="list-style-type: none"> • Other than Super Draft: i-ScreenFine • Super Draft: None 												
Thickness	80 to <u>220</u> to 1300 um	Enter the thickness of the media being loaded. If the setting has already been made in the “Adjust Print” menu, no input is required.	P.94											
Copy Media Type	Type1 to Type15, ALL	Copy the settings of the selected media type (Adjust Print, PF Adjust, each heater temperature, Vacuum fan, Print Mode, Thickness) to another media type. Selecting [ALL] will copy these settings to all media types.												

Adjust Print

Calibrate dot placement position in bidirectional printing. Ink landing position varies depending on print head height and media thickness. Make sure to run this calibration in the following cases:

- when you use this product for the first time
- when you changed to the different type of media

If the following symptom appears, you should also run this calibration:

- Image looks grainy or lines are blurry in bidirectional printing.

Note

This menu prints an adjustment pattern. More than 550 mm of printable width is required. If less than 550 mm, adjustment cannot be performed. Printable width on the media can be adjusted by changing CR origin (carriage moving direction) and side margin (left and right side margin) settings.

→ [\[Setup\] P.115](#) > [\[Media Width\] P.115](#) ,[\[Origin\] P.118](#) ,[\[Side Margin\] P.118](#)

Note

Heater warming up is performed before printing the pattern. **[Skip Heater Warm Up? No]** appears. You can start printing while heater warming up, but we do not recommend it because this can change the dot placement position.

→ [“Start printing during warm-up” P.79](#)

Caution

- ⊘ Do not touch the media guide while printing or when the message **[Warming Up]** appears on the panel. There is a risk of burns.

1 Load media into the printer.

→ [“Load the media into the printer” P.43](#)

Make sure to load it without any warps or curls.

2 Tap **[Home]** key.

3 Access the “Adjust Print” menu.

Menu flow



- Select **[Media Type]** and tap **[➤]** key.
- Use **[▲]** / **[▼]** key to select a media type and tap **[Enter]** key.
 - **[Adjust Print]** appears.

4 Tap [➤] key.
[Thickness:] appears.

5 Use [▲] / [▼] key to enter the thickness of the media and tap [Enter] key.

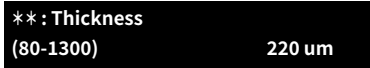

6 Use [▲] / [▼] key to select an adjustment method and tap [➤] key.

Normally run an Auto calibration. If performing the auto calibration does not improve print quality, perform manual calibration.

Auto	The color sensor reads the adjustment pattern print and the printer runs automatic “Adjust Print” calibration.
Standard	Print an adjustment pattern and enter the number of the pattern that has the least misalignment. Enter the thickness of media before adjustment. This option calibrates the print mode specified in the selected media type. Set the same print mode on the RIP software and media type.
Custom	Print an adjustment pattern and enter the number of the pattern that has the least misalignment. Enter the thickness of media before adjustment. This option calibrates all print modes. Even if the print mode set to the RIP software and media type is different, the printer will deliver optimum print quality.

 **Note**

- If you change the print mode after performing a calibration from **[Standard]**, make sure to perform “Adjust Print” calibration again.
- If you change the print mode after performing a calibration from **[Custom]**, there is no need to perform “Adjust Print” calibration again as it calibrates dot placement position for all print modes at once.
- If you want to use the different print mode in your RIP software from the mode specified in the media type, make sure to run “Adjust Print” calibration from **[Custom]** to check alignment in all adjustment patterns (A,C,and D) beforehand.

7 Follow these step to perform an adjustment.

- ➔ **“Adjust Print: When [Auto] is selected” P.96**
- ➔ **“Adjust Print: When [Standard] / [Custom] is selected” P.97**

Adjust Print: When [Auto] is selected

Note

The name of the selectable patterns differ between **[Auto]**, **[Standard]** and **[Custom]** adjustment. For details, see the menu list.

→ [\[Media Type\] P.92](#) > [\[Adjust Print\] P.92](#)

1 Use [▲] / [▼] key to select an adjustment pattern.

- **ALL**: Automatically runs calibration of all adjustment patterns.
- **Standard**: Automatically runs the same calibration as **[Standard]**.
- **Adjust Pattern ***: Automatically runs calibration of the selected adjustment pattern.

2 Tap [Enter] key.

The adjustment pattern printing and correction value input are carried out automatically.

3 Depending on the result, do one of the following:

■ If calibration has been successful

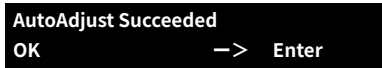

AutoAdjust Succeeded
OK → Enter

- Tap **[Enter]** key to exit the auto calibration.

■ If calibration has been failed

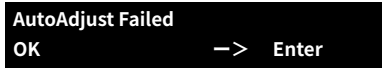

AutoAdjust Failed
OK → Enter

- Tap **[Enter]** key to exit the auto calibration. Run an Auto calibration again or perform calibration other than Auto.
→ [“Adjust Print: When \[Standard\] / \[Custom\] is selected” P.97](#)
- The adjustment value for the pattern which has been failed to calibrate or has not been calibrated yet will not be saved in the printer.

Note

If performing an auto calibration does not improve print quality (banding or graininess appears), perform **[Standard]** or **[Custom]** calibration.

→ [“Adjust Print: When \[Standard\] / \[Custom\] is selected” P.97](#)

Adjust Print: When [Standard] / [Custom] is selected

Note

The name of the selectable patterns differ between [Auto], [Standard] and [Custom] adjustment. For details, see the menu list.

→ [\[Media Type\] P.92](#) > [\[Adjust Print\] P.92](#)

Confirm pattern

1 Print a confirmation pattern.

Select [**Confirm Pattern**] from Standard or Custom calibration and tap [**Enter**] key.

- The printer begins printing a confirmation pattern.

2 Look at the print and check if there is no misalignment in the pattern.

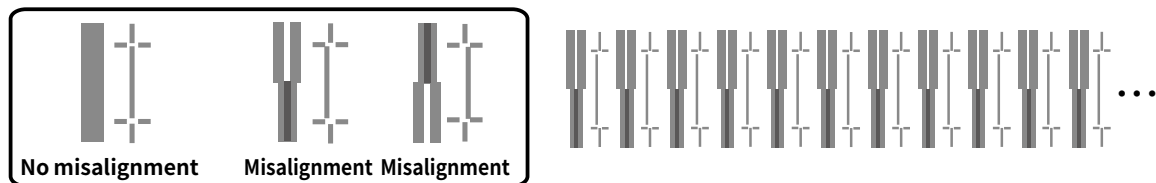

- If no misalignment exists, tap [**Enter**] key to end the calibration.
- If misalignment occurs, follow these steps to run a calibration.
 - If the amount of misalignment is large: Perform an adjustment with rough pattern.
→ [“Rough pattern” P.98](#)
 - If the amount of misalignment is small: Perform an adjustment with fine pattern.
→ [“Fine pattern” P.99](#)

⦿ Rough pattern

1 Print a rough pattern.

■ When [Standard] is selected

Select [**Rough Pattern**] and tap [**Enter**] key.

■ When [Custom] is selected

Select a pattern from [**Rough Pattern ALL**], [**Rough Pattern A**], [**Rough Pattern C**] or [**Rough Pattern D**] and tap [**Enter**] key.

2 Check the printed pattern and select the number written under the pattern that has the least misalignment.

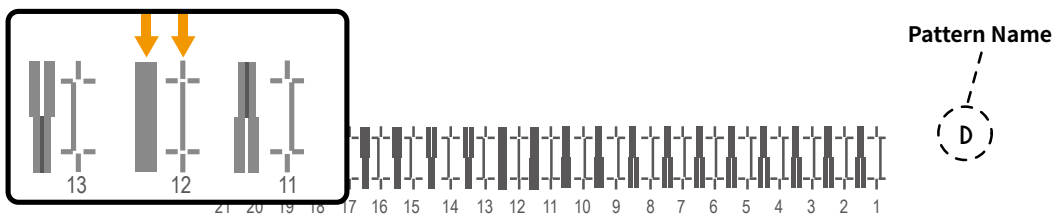

3 Use [**▲**] / [**▼**] key to select the number of the pattern with no misalignment and tap [**Enter**] key.

- For the above illustration, you will enter [**Pattern D: 12**].

```
** : PatternD
(1-21)                12
```

- When selecting [**Custom**] > [**Rough Pattern ALL**], you will enter a number for each pattern A, C and D.

4 Next, perform an adjustment with “Fine Pattern”.

→ **“Fine pattern” P.99**

Fine pattern

1 Print a fine pattern.

■ When [Standard] is selected

- Select [**Fine Pattern**] and tap [**Enter**] key.

■ When [Custom] is selected

- Select a pattern from [**Fine Pattern ALL**], [**Fine Pattern A**], [**Fine Pattern C**] or [**Fine Pattern D**] and tap [**Enter**] key.

2 Check the printed pattern and select the number written under the pattern that has the least misalignment.

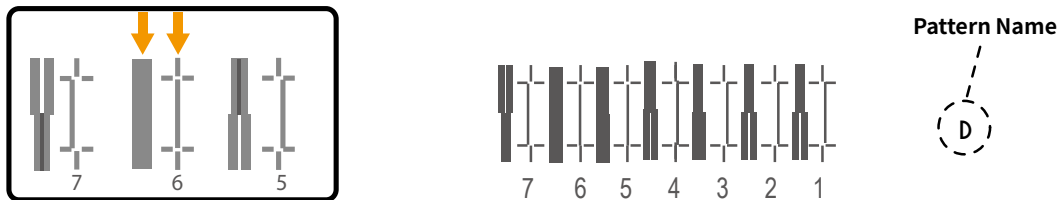

3 Use [^] / [V] key to enter the number of the pattern with no misalignment.

- For the above illustration, you will enter [**Pattern D: 6**].

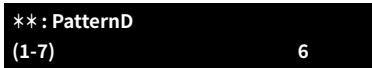

- When selecting [**Custom**] > [**Fine Pattern ALL**], you will enter a number for each pattern.

4 Tap [Enter] key.

End the calibration.

Adjustment pattern corresponding to print mode

Print Mode	Adjustment Pattern
Ex High Quality	C
High Quality	C
Quality	D
Production	D
Banner	D
Draft	D
Super Draft	D

Note

Pattern A and C should be selected only when the carriage speed is set to [**Low speed**] in your RIP software. The name of "Carriage Speed" option may vary depending on the RIP software.

Media feed adjustment

This adjustment corrects the media feed amount. Make sure to run this calibration in the following cases:

- when you use this product for the first time
- when you changed to the different type of media
- when you changed the pressure of pressure rollers

If the following symptom appears, you should also run this calibration:

- White or dark-colored lines appear on an image in the carriage moving direction.

Note

This menu prints an adjustment pattern. More than 400 mm of printable width is required. If less than 400 mm, adjustment cannot be performed. Printable width on the media can be adjusted by changing CR origin (carriage moving direction) and side margin (left and right side margin) settings.

→ [\[Setup\] P.115](#) > [\[Media Width\] P.115](#) ,[\[Origin\] P.118](#) ,[\[Side Margin\] P.118](#)

Note

Heater warming up is performed before printing the pattern. **[Skip Heater Warm Up? No]** appears. You can start printing while heater warming up, but we do not recommend it because this can change the dot placement position.

→ ["Start printing during warm-up" P.79](#)

Caution

- ⊘ Do not touch the media guide while printing or when the message **[Warming Up]** appears on the panel. There is a risk of burns.

1 Load media into the printer.

→ ["Load the media into the printer" P.43](#)

Make sure to load it without any warps or curls.

2 Tap **[Home]** key.

3 Access the "PF Adjust" menu.

Menu flow



- Select **[Media Type]** and tap **[>]** key.
- Use **[▲]** / **[▼]** key to select a media type and tap **[Enter]** key.
- Use **[▲]** / **[▼]** key to select **[PF Adjust]**.

4 Tap [➤] key.

5 Use [▲] / [▼] key to select an adjustment method and follow these steps to calibrate.

Normally run an Auto calibration. If performing the auto calibration does not improve print quality, perform manual calibration.

Auto	The color sensor reads the adjustment pattern print and the printer runs automatic “PF Adjust” calibration.		→ “Run an automatic media feed adjustment” P.102
	<ul style="list-style-type: none"> The adjustment value of the automatic media feed adjustment will be added to “Adjustment” for the manual media feed adjustment. The value in “Adjustment” for the manual distance adjustment may be reset. 		
Print	Print an adjustment pattern and enter an optimal adjustment value.		→ “Run a media feed adjustment manually” P.103
Adjustment	Enter an adjustment value and print a confirmation pattern.		
Adjust Distance	Print	Print an adjustment pattern with specified length.	
	Adjustment	Measure the printed pattern and enter the measured length.	
	Confirm Print	Print a confirmation pattern for verification.	

Run an automatic media feed adjustment

- 1 Tap **[Enter]** key so that the automatic media feed adjustment begins.

```
** : PF Adjust1
Auto
```

- An adjustment pattern will be printed.
- The color sensor reads the adjustment pattern and the printer automatically runs adjustment.

- 2 Depending on the result, do one of the following:

- **If calibration has been successful**

```
AutoAdjust Succeeded
OK -> Enter
```

- Tap **[Enter]** key to exit the auto calibration.

- **If calibration has been failed**

```
AutoAdjust Failed
OK -> Enter
```

- Tap **[Enter]** key to exit the auto calibration. Run a “PF Adjust” calibration manually.
→ [“Run a media feed adjustment manually” P.103](#)

 **Note**

If white or dark colored line still appears even after auto adjustment, perform a “PF Adjust” calibration manually.

→ [“Run a media feed adjustment manually” P.103](#)

Run a media feed adjustment manually

Manual media feed adjustment can be performed using the following methods. Select an appropriate correction method according to your printing purpose.

- **“Media feed adjustment” P.103**
Minimizes horizontal banding in the prints.
- **“Adjust Distance” P.105**
Corrects the error in the printing length when there is discrepancy in dimensions.

Media feed adjustment

You will print an adjustment pattern and then check and enter an adjustment value.

If you already know the adjustment value (such as media replacement), enter the adjustment value in “Adjustment”.

→ **“If you already know the adjustment value” P.104**

1 Run the “Print” menu.

Select [***: PF Adjust2 Print**] and tap [**Enter**] key.

- An adjustment pattern will be printed. Next you will enter an adjustment value.

2 Check the printed pattern and enter an adjustment value using [**^**] / [**V**] key.

Select the pattern that has the least white or dark-colored lines. The value written under the pattern is the adjustment value.

Note

Once the adjustment value has been entered, the value will become the reference value to be printed in the center of the pattern from the next print.

For example, if you have saved [**-0.20**] and print an adjustment pattern, values printed below block pattern will be changed to (from left) +1.00, +0.60, +0.30, 0.00, -0.20 (reference value), -0.30, -0.40, -0.70, -1.00, -1.40.

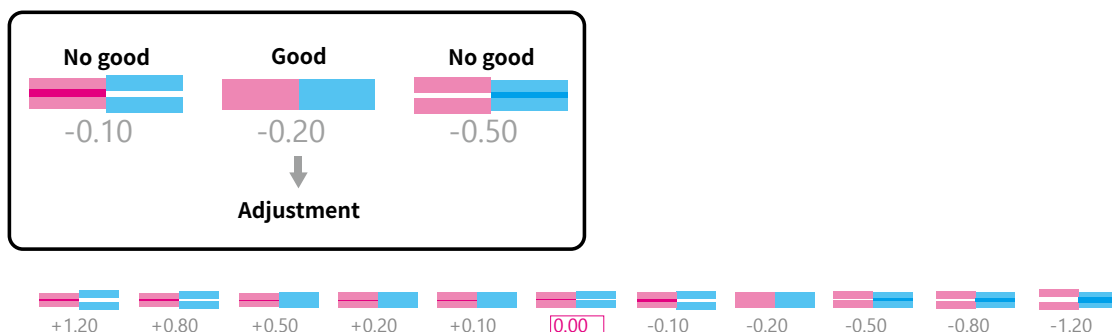

3 Tap **[Enter]** key to finish the adjustment.

If you already know the adjustment value

1 Enter an adjustment value in “Adjustment”.

- a. Select **[**: PF Adjust3 Adjustment]** and tap **[>]** key.
 - b. Use **[^]** / **[v]** key to enter the adjustment value and tap **[Enter]** key.
-

2 Do one of the following:



- To print a confirmation pattern, tap **[Enter]** key. Check the printed pattern and make a correction if needed.
 - If there is no need to print a confirmation pattern, use **[^]** / **[v]** key to select **[No]** and tap **[Enter]** key.
-

Adjust Distance

You will need a ruler for this adjustment. Use your personal ruler.

If this adjustment is performed, the values in [PF Adjust 3] > [Adjustment] and [Adjust Distance2] > [Adjustment] will be reset.

1 Run the "Print" menu.

- a. Select [**: Adjust Distance1 Print] and tap [➤] key.
 - [FeedLength] appears.
- b. Use [▲] / [▼] key to enter the media feeding length and tap [Enter] key.
 - An adjustment pattern will be printed.
- c. Cut it off the roll media (if needed).
 - "Cutting Media" P.80

Note

By default, the feed length is set to 250 mm. Increasing feed length will slightly improve accuracy of "PF Adjust" calibration.

2 Use a ruler to measure the distance between [†] marks printed.

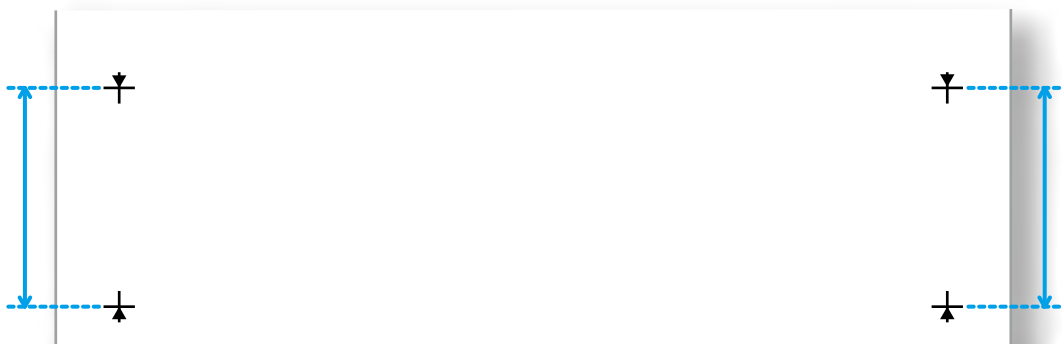

3 Enter an adjustment value in "Adjustment".

- a. Select [**: Adjust Distance2 Adjustment] and tap [➤] key.
- b. Use [▲] / [▼] key to enter the measured value and tap [Enter] key.

4 Run the “Confirm Print” menu.

- a. Select [******: **Adjust Distance3 Confirm Print**] and tap [**>**] key.
- b. Use [**▲**] / [**▼**] key to enter the media feeding length and tap [**Enter**] key.
 - An adjustment pattern will be printed.
- c. Cut it off the roll media (if needed).
→ “Cutting Media” P.80

Note

By default, the feed length is set to 250 mm. Increasing feed length will slightly improve accuracy of "PF Adjust" calibration.

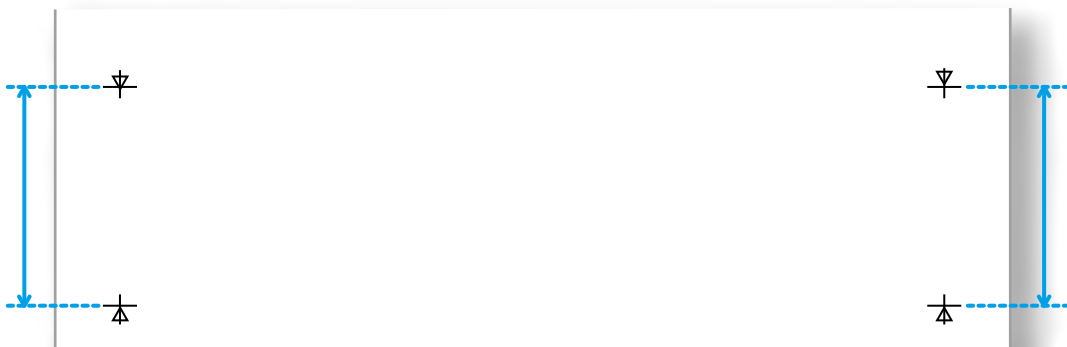
5 Use a ruler to measure the distance between [∇] marks printed.

- If the length being displayed and the measured distance match: End the calibration.
 - If the length being displayed and the measured distance do not match: Start over from “Print” (**Step**).
-

Menu2: Maintenance

Menu List

- Underlines in the setting range indicate the default settings.

	Setting range	Functions	→
Maintenance			
Cleaning [Short]		Consumes a small amount of ink.	P.58
Cleaning [Normal]		Select this mode if there are clogged nozzles.	
Cleaning [Long]		Select this mode if nozzle clogging persists even after repeated Cleaning [Normal] attempts.	
Other Maintenance			
CR Maintenance		Move the carriage and perform printer maintenance.	P.131
Soak Cleaning		Soak the print head in the maintenance cleaning solution filled in the head cap to clean dirt off the nozzle surface. Designated maintenance cleaning solution is required.	P.145
Little Charge		Gives high cleaning efficiency, but consumes a lot of ink.	P.144
Initial Charge		Offers more powerful cleaning than Little Charge, but consume large amount of ink.	
Longstore		Flush ink out of the print head.	P.164
Power Off		Turn off the printer.	P.42
Maintenance Setup			
Auto Cleaning		Set an automatic head cleaning operation. This will prevent nozzle clogging.	
Standby Mode		Sets the automatic cleaning to be performed in the print-ready state. Interval includes the time elapsed while the printer is powered off. Auto cleaning will not be performed while the printer is powered off, but will be performed when the printer is powered on the next time.	
Cleaning Type	Off, <u>Spitting</u> , Short, Normal, Long	Select the type of cleaning.	
Cleaning Interval	10 to <u>360</u> to 1440 min	Sets the timer for cleaning.	
While Printing		Sets the automatic cleaning to be performed during printing. When the scheduled time has passed, cleaning begins. Once cleaning is complete, printing will resume.	
Cleaning Type	<u>Off</u> , Short, Normal, Long	Select the type of cleaning.	
Cleaning Interval	5 to <u>180</u> min	Sets the timer for cleaning.	
Before Print		Sets the automatic cleaning to be performed before printing.	
Cleaning Type	<u>Off</u> , Short, Normal, Long	Select the type of cleaning.	

		Setting range	Functions	→
	Select Nozzle		If nozzle clogging still persists even after several cleaning attempts, you can select only active nozzles for printing.	P.148
	Print		Print a confirmation pattern.	
	Nozzle Area Select	<u>Nozzle All</u> , Nozzle A ,B ,C ,D ,E ,F	Select the nozzle area to use for printing.	
	Auto Nozzle Check	On, <u>Off</u>	When set to [On] , the sensor of the drop sensor unit checks condition of nozzles and if nozzle clogging is detected, the printer automatically performs a head cleaning. Since this menu does not print patterns, no media is consumed.	P.110
	<div style="border: 1px solid green; padding: 5px; margin-bottom: 5px;">  Note This menu will not be displayed when the optional drop sensor is not installed. </div>			
Number of print job	Off, <u>1</u> to 30 count	Frequency of automatic nozzle checking can be set by the number of print jobs.		
Select Nozzle	<u>On</u> , Off	When set to [On] , if nozzle clogging persists after 3 cleaning attempts based on automatic nozzle check result, the printer will automatically select and print using the nozzles currently fired ink properly.		

	Setting range	Functions	→
Sleep Mode		While in sleep mode, the printer performs automatic head cleaning regularly.	P.40
Cleaning Setting		Sets the automatic head cleaning to be performed during sleep mode.	
Cleaning Type	Short, Normal, Long	Select the type of cleaning. Tapping [Enter] key will move to the Cleaning Timer menu.	
Cleaning Timer	12h, 1, 2, 3, 4, 5, 6, 7day	Sets the timer for cleaning.	
Auto Sleep Timer	4, 8, 12, 24 h	Set the timer to automatically enter sleep mode if no printing is performed for certain period.	
Start		<p>Start the sleep mode.</p> <ol style="list-style-type: none"> 1. Tap [>] key. <ul style="list-style-type: none"> - [Sleep Mode Start →Enter] appears. 2. Tap [Enter] key to start sleep mode. <ul style="list-style-type: none"> - [Sleep Mode End →Enter] appears. <div style="border: 1px solid #92d050; padding: 5px; margin-top: 10px;"> <p>Note</p> <p>Sleep mode cannot be started in the following cases:</p> <ul style="list-style-type: none"> • A error is occurring (Ink End, No Bag, Full Waste Ink Tank, Cover Open, etc.) • Printer is running (during Media Initial, printing, etc.) </div> <ol style="list-style-type: none"> 3. To wake up from sleep mode, tap [Enter] key. 	

Automatic nozzle checking (when optional drop sensor unit is installed)

This function is available when the optional "drop sensor unit" is installed in the printer.

→ **"Drop Sensor Unit Operation Manual"**.

When set to **[On]**, the sensor of the drop sensor unit checks condition of nozzles at the following timing and if nozzle clogging is detected, the printer automatically performs a head cleaning.

- When powered on
- When waking up from sleep mode
- before the first print after the "Number of print job" setting was specified and each time before printing the specified number of print jobs

If nozzle clogging still persists even after three cleaning attempts, the printer will automatically select a nozzle segment that works properly to continue printing.

Important!

- To use the Auto Nozzle Check function, make sure to set the head height to "Low1", "Low2" or "Middle" and attach a black cleaning wiper (normal type).

This function does not work with the head height "High" setting.

Also, Mutoh does not guarantee this function to use with a grey wiper (for head height High) attached.

- The following symptom may occur depending on the type of ink being used or when the printer is used outside the scope of **"Specifications" P.193**.

- The printer performs cleaning cycle each time an automatic nozzle check is run (this will consume more ink).
- Automatic nozzle checking takes longer.
- Even if an automatic nozzle checking was performed, nozzle clogging appears on the print.*

* If nozzle clogging persists, run a nozzle check and cleaning manually.

→ **"Nozzle check and head cleaning" P.56**

- This function does not guarantee 100 percent prevention of nozzle clogging.

Note

When Auto Nozzle Check is set to **[On]** while there are clogged nozzles that cannot be cleared by cleaning, automatic cleaning cycle will be performed every time the printer runs an automatic nozzle check so that ink consumption will increase.

To avoid this, select the nozzle pattern that has no nozzle clogging from "Select Nozzle" beforehand and then set the auto nozzle check to **[On]**.

→ **"Select Nozzle" P.148**

Note

The MPS function will be disabled if properly firing nozzles have been automatically selected by automatic nozzle checking.

Automatic nozzle check flow

- 1 The sensor of the drop sensor unit checks condition of nozzles.

Auto nozzle checking

Note

- Tapping [**Cancel**] key will cancel an automatic nozzle check.
- Normally the detection takes about 3 to 5 minutes, but it may take longer according to the number of clogged nozzles.

- 2 If a nozzle clogging was detected, the printer performs a head cleaning.

Cleaning ** %

- Steps 1 and 2 are repeated until the clogging is clear. (maximum 3 sets)

- 3 If nozzle clogging still persists even after three cleaning attempts, the printer will automatically select a nozzle pattern with no clogging.

Print Ready
PG: Low1 Select Nozzle: A

- This allows printing using only active nozzles.
- In ready-to-print state, the nozzle pattern (alphabet) selected automatically will appear on the control panel. If the nozzle pattern is selected from "**Select Nozzle**" P.148, the display returns to [**Media Width**].

- 4 In case nozzle clogging still persists, the message [**Auto Nozzle Check Nozzle Clog Present**] will appear.

Auto Nozzle Check
Nozzle Clog Present

- If the print job has already been sent to the printer, the job that nozzle clogging was detected will be deleted and the rest of the print jobs will be on hold. Delete the job being on hold using the computer that you sent the job, then manually run a nozzle check and cleaning.
 - "**Nozzle check and head cleaning**" P.56
- MUTOH recommends you to clear the clogged nozzles and then print the job again.
- Tapping [**Enter**] key will clear the display and continue printing the held job with clogged nozzles.

Menu3: Test Print

Menu List

- Underlines in the setting range indicate the default settings.

	Setting range/ Submenu	Functions	→
Test Print			
Nozzle check		Prints a nozzle check pattern using the nozzles selected from “Nozzle Area Select”.	P.56
Nozzle check F		Prints a nozzle check pattern using all nozzles.	
Media Adjustment	<u>Type1</u> to Type15	Automatically runs “Adjust Print” and “PF Adjust” calibration.	P.113

Media Adjustment

Automatically runs “Adjust Print” and “PF Adjust” calibration.

→ [“Adjust Print” P.94](#), [“Media feed adjustment” P.100](#)

Note

This menu prints an adjustment pattern. More than 550 mm of printable width is required. If less than 550 mm, adjustment cannot be performed. Printable width on the media can be adjusted by changing CR origin (carriage moving direction) and side margin (left and right side margin) settings.

→ [\[Setup\] P.115](#) > [\[Media Width\] P.115](#) , [\[Origin\] P.118](#) , [\[Side Margin\] P.118](#)

Note

Heater warming up is performed before printing the pattern. **[Skip Heater Warm Up? No]** appears. You can start printing while heater warming up, but we do not recommend it because this can change the dot placement position.

→ [“Start printing during warm-up” P.79](#)

Note

The media type and media thickness selected in “Media Adjustment” will be saved in the printer.

Caution

 Do not touch the media guide while printing or when the message **[Warming Up]** appears on the panel. There is a risk of burns.

1 Load media into the printer.

→ [“Load the media into the printer” P.43](#)

Make sure to load it without any warps or curls.

2 Tap **[Home]** key.

3 Access the “Media Adjustment” menu.

Menu flow



- **[^]** / **[v]** key: Select a menu item.
- **[>]** key: Enter the menu.

4 Tap **[>]** key.

5 Select a media type and tap **[Enter]** key.

Media Type:
Type** OK?

6 Use **[^]** / **[v]** key to enter the thickness of the media.

** : Thickness
(80-1300) 220 um

 **Note**

The change made here is saved in the media type.

7 Tap **[Enter]** key.

Automatic adjustment begins.

** Accur. Adjust Print **
PG: Low1 W: 1625 mm

8 Depending on the result, do one of the following:

■ **If calibration has been successful**

AutoAdjust Succeeded
OK → Enter

- Tap **[Enter]** key to exit the auto calibration.

■ **If calibration has been failed**

AutoAdjust Failed
OK → Enter

- Tap **[Enter]** key to exit the auto calibration. If calibration has been failed, run a calibration manually.
- **“Adjust Print” P.94, “Media feed adjustment” P.100**
- The adjustment value for the pattern which has been failed to calibrate or has not been calibrated yet will not be saved in the printer.

 **Note**

- If performing an auto calibration does not improve print quality (banding or graininess appears), redo the Auto Adjustment or perform other adjustment.
- The values of currently selected media type will be reflected to initial values of media type and media thickness.

Menu4: Setup menus

Menu List

- Underlines in the setting range indicate the default settings.

	Setting range	Functions	→
Setup			
Media Initial	Off, <u>Top&Width</u> , <u>Width</u>	Select how the printer detects the width of media. <ul style="list-style-type: none"> • Off: No media detection is performed. Enter the media width in the “Media Width” menu. • Top&Width: Automatically detects the width and the leading edge of media. • Width: Automatically detects media width. 	
Media Width	210 to <u>1370</u> to 1625 mm	Enter the width of media being loaded. If the Media Initial menu is set to [Top & Width] or [Width] , the media width that the printer automatically detected will be displayed.	
Output Mode	<u>Off</u> , Take Up, Auto Cut	Select the how the printed media is processed. <ul style="list-style-type: none"> • Off: Select this when you do not use the take-up unit. • Take Up: The take-up unit winds the media. • Auto cut: Automatically cuts media after printing. 	
Page Gap	<u>Normal</u> , Narrow	Margin between pages can be changed. This menu appears only when the Output Mode is set to [Take Up] .	
Ink Dry Timer	<u>0 sec</u> to 60 min	Set the time interval between after printing and before next printing for ink drying. Next printing will start when the specified time has passed.	
Method of Cut	Single Cut - 2 steps, <u>Single Cut - 3 steps</u> , Double Cut - 2 steps, Double Cut - 3 steps	Sets the media cut operation after printing. <ul style="list-style-type: none"> • Single Cut - 2 steps: Cut with less process than "Single Cut - 3 steps". Suitable for narrower width media. • Single Cut - 3 steps: Normal cutting method. • Double Cut - 2 steps: Select this when "Single Cut - 2 steps" cannot fully cut the media. • Double Cut - 3 steps: Select this when "Single Cut - 3 steps" cannot fully cut the media. <div style="border: 1px solid green; padding: 5px; margin-top: 10px;"> <p>Note</p> <ul style="list-style-type: none"> • The printer does not perform media cutting when the “Media Initial” menu is set to [Off]. → [Media Initial] P.115 • This option may not cut off some types of media. In such cases, set the “Output Mode” menu to [Off] and cut the media manually. → [Output Mode] P.115 </div>	

		Setting range	Functions	→
	Cut Pressure	Low, <u>High</u>	Sets the pressure to cut the media. <ul style="list-style-type: none"> • Low: Select this mode, when the High mode gives too much pressure or when you are using thin media. • High: Normal cutting pressure. 	
	Standby Heating	10 ~ <u>60 min</u>	Sets the time to preheat the heater while in ready-to-print state. Each heater turns off when the set time has passed.	
	Slant Check	Off, <u>On</u>	The printer checks skew after printing. If media skew is detected, an error message will be displayed.	
	Heater Control	<u>Normal</u> , Fixer	Sets heater operation. <ul style="list-style-type: none"> • Normal: Printing starts when the heater reaches the specified temperature. Use this option when you do not experience media cockling. • Fixer: Printing starts before the heater reaches the specified temperature. Printing colors may change. 	
	Prevent Stick	Off, <u>On</u>	Feed media back and forth before printing to prevent media sticking. This menu will be disabled when the “Output Mode” menu is set to [Take Up] . <ul style="list-style-type: none"> • Media feed length when set to [On]: 200 mm 	
	Exhaust Fan	Off, <u>Low</u> , High	Exhausts the air inside the printer. It also removes ink mist from the inside, reducing contamination inside the printer. It is recommended to turn it on for long printing runs.	
	Start Feed	-10 to <u>0</u> to 500 mm	Sets the margins between print data. <div style="border: 1px solid green; padding: 5px; margin-top: 10px;"> <p> Note</p> <ul style="list-style-type: none"> • When the “Output Mode” menu is set to [Off], the margin between print data will be the specified length plus 10 mm. • When the “Output Mode” menu is set to [Take Up], the margin between print data will be the specified length. • Margins between print data are set at 10 mm. <p>→ “Printing area” P.32</p> </div>	

	Setting range	Functions	→
Header Dump	<u>Off</u> , On, Dump, Print	<p>Select whether to print the dump information for the print data; (Data header/ Data dot number/ print time/ printer serial number/ firmware version/ receiving time/ receiving size).</p> <ul style="list-style-type: none"> • Off: Dump data will not be printed. • On: The printer prints an image data followed by dump information. “Receiving time” and “Receiving size” will not be printed. • Dump: The printer prints dump information except data dot number. • Print: The printer prints the last dump data. “Receiving time” and “Receiving size” will not be printed. If there is no dump information in the history, [No Print Data] will be displayed. <div style="border: 1px solid green; padding: 5px; margin-top: 10px;"> <p> Note</p> <ul style="list-style-type: none"> • Please provide the dump data when you receive technical support. • When you are printing through computer, the print settings configured in the RIP software will be printed in "Data header". </div>	
Print preferences			
Spitting	<u>On</u> , On Media, Off	<p>Enable or disable the ink flushing maintenance. Flushing is the print head maintenance to avoid nozzle clogging. It consumes a slight amount of ink.</p> <ul style="list-style-type: none"> • On: Perform an ink flushing on the flushing box. MUTOH cannot guarantee print quality if the Pass Count menu is set to more than [1]. Normally it should be set to [1]. • On Media: Select this to perform an ink flushing on the flushing box and media margins. The maximum printing width will be reduced by 16 mm. → [Side Margin] P.118 • Off: Printer does not perform an ink flushing maintenance. Nozzle gets clogs easily. Normally, do not select [Off]. 	

		Setting range	Functions	→													
	Pass Count	<u>1</u> to 2 to 999 cnt	<p>Specify the interval to perform flushing in the flushing box. This menu is not displayed when the "Spitting" menu is set to [Off].</p> <table border="1"> <thead> <tr> <th>Spitting</th> <th>Pass Count</th> <th>Operation</th> </tr> </thead> <tbody> <tr> <td rowspan="2">On</td> <td>1 cnt</td> <td>Printer performs ink flushing on the flushing box each time the print head travels back and forth.</td> </tr> <tr> <td>5 cnt</td> <td>Printer performs ink flushing on the flushing box once the print head travels back and forth five times.</td> </tr> <tr> <td rowspan="2">On Media</td> <td>1 cnt</td> <td>Printer performs ink flushing on the flushing box and on the media margin each time the print head travels back and forth.</td> </tr> <tr> <td>5 cnt</td> <td>Printer performs ink flushing on the flushing box once the print head travels back and forth five times. Flushing is performed on the media margin each time the print head travels back and forth.</td> </tr> </tbody> </table>	Spitting	Pass Count	Operation	On	1 cnt	Printer performs ink flushing on the flushing box each time the print head travels back and forth.	5 cnt	Printer performs ink flushing on the flushing box once the print head travels back and forth five times.	On Media	1 cnt	Printer performs ink flushing on the flushing box and on the media margin each time the print head travels back and forth.	5 cnt	Printer performs ink flushing on the flushing box once the print head travels back and forth five times. Flushing is performed on the media margin each time the print head travels back and forth.	
Spitting	Pass Count	Operation															
On	1 cnt	Printer performs ink flushing on the flushing box each time the print head travels back and forth.															
	5 cnt	Printer performs ink flushing on the flushing box once the print head travels back and forth five times.															
On Media	1 cnt	Printer performs ink flushing on the flushing box and on the media margin each time the print head travels back and forth.															
	5 cnt	Printer performs ink flushing on the flushing box once the print head travels back and forth five times. Flushing is performed on the media margin each time the print head travels back and forth.															
	Side Margin	5 to <u>6</u> to 25 mm	<p>Sets the left and right margins of the media.</p> <div style="border: 1px solid green; padding: 5px; margin-bottom: 10px;"> <p>Important!</p> <p>When you swapped left and right edge holders, set the side margin to more than 11 mm because ink may stain on the overlapping part of the edge holder and media.</p> <p>→ "Change the way to use the edge holder depending on the media being used" P.64</p> </div> <div style="border: 1px solid green; padding: 5px;"> <p>Note</p> <p>When the "Spitting" menu is set to [On Media], the maximum print width will be 16 mm shorter. The left and right margins are [set value + 8 mm].</p> <p>→ "Spitting" P.117</p> </div>														
	Origin	PF, CR	Sets the print start position (origin).	P.120													
	Head Travel	Data, Machine, <u>Media</u>	<p>Select the width that the print head travels for printing.</p> <ul style="list-style-type: none"> • Data: Travels the data width. • Machine: Travels the maximum printable area. • Media Width: Travels the media width. 														
	Multi Strike	<u>1</u> to 9 cnt	Specify the number of times the printer prints the same line. Increase the number of times if you want to print on transparent media.														
	Pass Wait	<u>0.0</u> to 5.0 sec	Sets the time to pause the carriage each time it scans. When ink does not dry easily such as overprinting, it helps to improve ink bleeding.														

	Setting range	Functions	→
Front Interlace	<u>Auto</u> , Off	Fine tune the media feed amount to improve print quality of the beginning of the print. Normally use [Auto] . However, in the following cases, setting it to [Off] may improve print quality. <ul style="list-style-type: none"> • When poor print quality due to nozzle clogging is observed at the beginning of the print. • If there is a difference in print quality between the beginning of the print and the rest of the print when printing with [Auto] setting. 	
Initialization		Restore the settings of the printer to the factory defaults.	
ALL		Reset all the settings.	
Media Type		Reset all the settings in [Media Type] .	
Except Media Type		Reset all settings except [Media Type] .	
Initial Settings			
Language	<u>English</u> , Dutch, Spanish, French, Italian, Portuguese, German, Japanese	Select the language to be displayed on the control panel.	
Temperature	<u>Celsius [°C]</u> , Fahrenheit [°F]	Select the unit of temperature to be used on the display of the control panel.	
Length	<u>mm</u> , inch	Select the unit of length to be used on the display of the control panel.	
IP Address	0.0.0.0 to <u>192.168.1.253</u> to 255.255.255.255	<div style="border: 1px solid green; padding: 5px;"> <p>Important!</p> <p>Make sure to consult your network administrator before setting the IP address, subnet mask, and gateway of the printer.</p> </div>	
Subnet Mask	0.0.0.0 to <u>255.255.255.0</u> to 255.255.255.255		
Gateway	0.0.0.0 to <u>192.168.1.254</u> to 255.255.255.255		
Alert Buzzer	Off, <u>On</u>	Select how the alert buzzer beeps when an error occurs. <ul style="list-style-type: none"> • Off: The buzzer beeps a certain number of times and then stops. This prevents the alert buzzer from sounding continuously at night when unattended. • On: The buzzer beeps continuously. 	
LED Light	<u>Auto</u> , On, Off	Sets the operation of internal LED lights. <ul style="list-style-type: none"> • Auto: Internal LED lights turn on automatically. It turns on while printing, cover open, detecting media, cutting media, feeding media or setting origin. • On: Internal LED lights turn on all the time. However, it turns off during sleep mode or when the printer is turned off. • Off: Internal LED lights turn off all the time. 	

Origin setting

The Origin menu allows you to change the print start position of print data. Use this option when you want to print an image on the blank space of the already printed media by changing layout.

1 Tap **[Home]** key.

2 Access the “Origin” menu.

Menu flow



- **[▲]** / **[▼]** key: Select a menu item.
- **[>]** key: Enter the menu.

3 Tap **[>]** key.

4 Sets the print start position (origin).

- **[▲]** / **[▼]** key: PF (media feeding) direction
 - Setting range: -15,000 mm to 15,000 mm (setting range will be 0 mm to 15,000 mm when the "Output Mode" menu is set to **[Take Up]**)
- **[<]** / **[>]** key: CR (carriage moving) direction
 - Setting range: 0 mm to 1,405 mm*¹

```
Origin:
PF:      0   CR:      0
```

5 Tap **[Enter]** key.

The media and carriage will move to the specified position.

6 Tap **[Enter]** key to finish the procedure.

```
Confirm Position:
End      -> Enter
```

Note

- *1 The maximum setting range in the CR (carriage moving) direction depends on the width of media.
 - Maximum setting range in the CR direction = Media width - Side margin settings (left and right total) - 210 (Minimum required print area)

Example: when the media width is 1625 mm and side margin is 5mm,

 - Maximum setting range in the CR direction = 1625 - (5x2) - 210 = 1405 (mm)

→ [\[Setup\] P.115](#) > [\[Side Margin\] P.118](#)
- The margin on the right side of the media will be the sum of the values below.
 - The amount of change in the CR (carriage moving) direction + side margins (left and right total) *2

*2 When **[Spitting]** is set to **[On Media]**, add 8 mm to the above value.

→ [\[Setup\] P.115](#) > [\[Side Margin\] P.118](#) , [\[Spitting\] P.117](#)

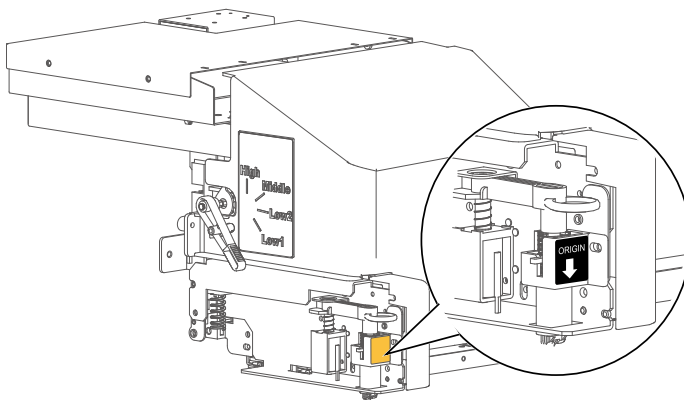

The arrow mark on the Origin label shows the current print start position in CR (carriage moving) direction.

Origin default setting

- ① CR (carriage moving) direction: 6 mm from the right edge of the media
- ② PF (media feeding) direction: approximately 95 mm from the cutting groove on the platen (③)

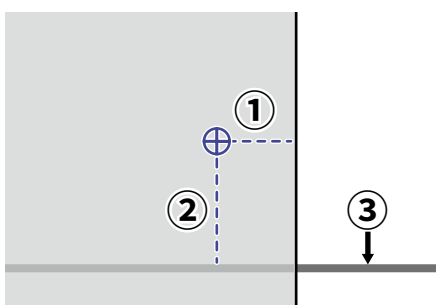

Menu5: Roll Length Manage

This menu allows you to manage the remaining length information of roll media by printing this information with text and code on the roll media and reading the code when the media is loaded next time.

Note

- “Print” or “Simple Print” requires at least 400 mm printable width. The printer is unable to print if printable width is less than 400 mm. (An error message will appear) Printable width on the media can be adjusted by changing CR origin (carriage moving direction) and side margin (left and right side margin) settings.
 - [\[Setup\] P.115](#) > [\[Media Width\] P.115](#) ,[\[Origin\] P.118](#) ,[\[Side Margin\] P.118](#)
- In the following cases, you will not be able to run the menu other than “Roll Length Manage” . (An error message will appear)
 - “Media Initial” is set to **[Off]**
 - [\[Setup\] P.115](#) > [\[Media Initial\] P.115](#)
 - When no media is detected.
 - [“Load the media into the printer” P.43](#)

Menu List

- Underlines in the setting range indicate the default settings.

	Setting range/ Submenu	Functions	→
Roll Length Manage			
Print		After cutting the print off the roll media, print a roll remaining length management information (roll media type, remaining length, date printed, roll length management code) on the roll media. The printer is unable to print when “Roll Length” menu is set to [Off] .	
Simple Print		After cutting the print off the roll media, print a roll remaining length management information (roll media type, remaining length, date printed) on the roll media. The printer is unable to print when “Roll Length” menu is set to [Off] .	
Scan		Scan the roll length management code printed on the roll media. If the reading fails, the “Roll Length” menu will be displayed. Enter the length manually.	P.124
Roll Length	<u>Off</u> , roll 1, 2, 3	The length of roll media to be loaded can be entered (up to 3 roll media) . Selecting one other than [Off] and tapping [Enter] key will go to the “Length” menu.	
Length	1 m to <u>45 m</u> to 1500 m	Length of roll media can be entered by 1 m increments. Tapping [Enter] key will move to the “Print Stop” menu.	

		Setting range/ Submenu	Functions	→
	Print Stop	<u>Off</u> , On	<p>Select whether to pause printing when the remaining roll length counter reached zero.</p> <ul style="list-style-type: none"> • Off: Printing pauses when the rear sensor detects the rear end of the media. • On: When the remaining length counter reached 0, the printer gives [Roll Remain Error] message and pauses printing. If a roll media does not release easily from the paper core, you should select [On]. In the [On] setting, tapping key will go to the “Near End” menu. 	
	Near End	<u>Off</u> , 1 to 10 m	<p>Select whether to display the remaining roll length on the control panel before the counter reaches zero.</p> <ul style="list-style-type: none"> • Off: Remaining length is not displayed. • Remain **m (** can be specified between 1 to 10): [Near End] will be displayed when the counter reaches the length you specified. 	
	Auto Scan	<u>Off</u> , On	<p>Select whether or not the printer automatically scans the remaining length management code.</p> <ul style="list-style-type: none"> • Off: The printer does not automatically scan the remaining length management code. • On: The printer automatically scans the remaining length management code when <ul style="list-style-type: none"> - powered on. - you replace media. <p>Tapping [Cancel] key while scanning will cancel the scan.</p> <div style="border: 1px solid green; padding: 5px; margin-top: 10px;"> <p>Note</p> <ul style="list-style-type: none"> • The printer may fail to scan if a remaining length management code has dirt or fold marks on it. In case failed to scan the code, manually specify the Roll Length settings based on the remaining length management information printed in text on the media. <p>→ [Roll Length] P.122</p> • If the printer does not read the code even when “Auto Scan” is set to [On], check whether the following settings are [Off] or [Auto Cut]. <p>→ [Media Initial] P.115 , [Output Mode] P.115</p> </div>	
	Auto Print	<u>Off</u> , On	<p>Select whether or not to prompt a confirmation message when you perform media cutting, asking you whether to print a remaining length management information on a roll media.</p> <ul style="list-style-type: none"> • Off: The message is not prompted. • On: After media cutting, the message [Print Roll's Remain?] will appear. Select [Yes] or [No] and tap [Enter] key. <div style="border: 1px solid green; padding: 5px; margin-top: 10px;"> <p>Note</p> <p>The “Auto Print” menu cannot be enabled when the “Roll Length” menu is set to [Off].</p> <p>→ [Roll Length] P.122</p> </div>	

Scan

- 1 Load a roll media that the remaining length management code has been printed on into the printer.

→ [“Load the media into the printer” P.43](#)

Make sure to load it without any warps or curls.

- 2 Check that the remaining length management code printed on the media has passed through the pressure rollers.

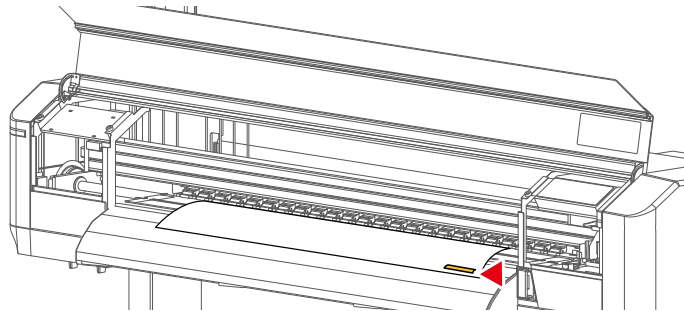

- 3 Tap **[Home]** key.

- 4 Access the “Scan” menu.

Menu flow



- **[▲]** / **[▼]** key: Select a menu item.
- **[>]** key: Enter the menu.

- 5 Tap **[Enter]** key to start reading.

- 6 When the printer scanned the code successfully, the following settings will automatically be specified in Roll Length:

- Type of roll media
- Remaining roll length

Note

- The printer may fail to scan if a remaining length management code has dirt or fold marks on it.
- The printer is unable to read the code when the “Output Mode” menu is set to **[Take Up]**.
- In case failed to scan the code, manually specify the Roll Length settings based on the remaining length management information printed in text on the media.

→ [\[Roll Length\] P.122](#)

Menu6: Printer Info.

Menu List

		Functions
Printer Info.		Displays printer information.
Printer Status		
Ink Status		<p>Displays the amount of ink remaining in each ink bag (Unit: %).</p> <ul style="list-style-type: none"> • Use genuine ink and smart chip cards. Ink status will not be displayed correctly if non-genuine products are used. • If the ink level is blinking at 10 %, smart chip recovery is being performed for the corresponding ink bag. <p>→ “Smartchip Recovery” P.179</p>
Life Times		<p>Displays remaining life of the following parts:</p> <ul style="list-style-type: none"> • Print head • Pump • CR motor • PF motor <p>The remaining part life is indicated by the asterisks (Maximum 5 asterisks: 100% left). As the part is nearing the end of its service life, the number of asterisks decreases one by one (20%).</p> <p>Example:</p> <ul style="list-style-type: none"> • [Pump: E*****F]: 100 to 80 % life remaining • [Pump: E** F]: 40 to 20 % life remaining • [Pump: E* F]: 20 % or less life remaining • [Pump: Change]: Request replacement of the part. When the part needs to be replaced, [Life Times [Pump]] will appear. Tapping [Enter] key will delete this message. This message will appear again after 7days.
Job Status		
	Status	Indicates whether printing is complete.
	ToDoLength	Displays the total length of print data (in media feed direction).
	Done	Displays the length of data printed.
	Remain	Displays the length of data which has not been printed yet.
Total Print Area		Displays the cumulative area printed from the time of purchase to the present.
System Info.		
	Version	Displays the firmware version (M: main firmware, C: controller firmware).
	Printer Model	Displays the printer model name.
	Serial Number	Displays the serial number of the printer.
	Ink Type	Displays the ink type loaded on the printer.

4 Maintenance

About Maintenance	127
Regular Maintenance	132
Emptying waste ink tank	138
Maintenance based on your usage	140
Replace the consumable parts	152
Moving or transporting the printer	161
Long-term storage	164

About Maintenance

To maintain your printer performance, please conduct maintenance by yourself.

Type of maintenance and frequency

Regular Maintenance

Maintenance that must be performed daily or periodically

Timing	Menu
Before and after daily operation	“Nozzle check and head cleaning” P.56
Once a week	<ul style="list-style-type: none"> • “Cleaning of the cleaning wiper” P.132 • “Cleaning of the parts around the capping unit” P.134 • “Soak Cleaning” P.145 (Recommended)
Once a month	“Cleaning inside the printer” P.136
When the message is prompted	“Emptying waste ink tank” P.138

Maintenance based on your usage

Please perform this maintenance at an appropriate time based on your printer status.

Timing	Menu
When nozzle clogging occurred	“Head cleaning” P.140
Nozzle clogging persists even after several head cleaning attempt	<ul style="list-style-type: none"> • “Cleaning of the cleaning wiper” P.132 • “Cleaning of the parts around the print head” P.141
If severe nozzle clogging occurred	<ul style="list-style-type: none"> • “Little Charge” P.144 • “Soak Cleaning” P.145 • “Select Nozzle” P.148
When auto adjustment fails repeatedly in the Adjust Print calibration.	“Clean the color sensor” P.150
When printer is not used for a long period	“Long-term storage” P.164

🔍 Replace the consumable parts

To ensure consistent print quality, replace the following parts at the appropriate time.

Timing	Menu
About two months (Please check periodically as it depends on your usage)	“Replace the flushing box pad” P.152
<ul style="list-style-type: none"> • When unable to cut media cleanly • When the cut is fuzzy or not straight. 	“Replace the Cutter” P.155
About 12 months	“Replace the Cleaning Wiper” P.158

📢 Important!

In the following cases, please contact your local MUTOH dealer to request service personnel.

- The same system error occurred repeatedly.
 - The message notifying the life of motors, various pumps, or print head is displayed on the control panel.
- [“Messages and Error Messages” P.174](#)







Preparations for maintenance

! Make sure to read the following sections before this maintenance.

→ “About Maintenance” P.16

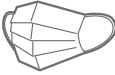
→ “Ink and waste fluid” P.17

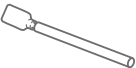
What you need

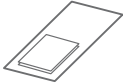
 <p>Protective goggles</p>	 <p>Polyethylene gloves</p>	 <p>Protective mask</p>	 <p>Protective clothing</p>	 <p>Cleaning stick</p>
 <p>Dropper</p>	 <p>Maintenance cleaning solution</p>	 <p>Paper towel</p>		

Note

- Please use the paper towels supplied with the product or the optional poly-knit wiper.
- Do not use tissue paper. Lint or flakes on tissue may cause the print head to malfunction.
- Do not use non-designated maintenance cleaning solution.
- To purchase the optional accessories such as designated maintenance cleaning solution, please contact your local MUTOH dealer.

Wearing protective equipment

When performing the following maintenance, wear protective equipment such as supplied gloves (or solvent-resistant gloves) and protective goggles.

- “Checking ink level and replacing ink bag” P.83
- “Cleaning of the cleaning wiper” P.132
- “Cleaning of the parts around the capping unit” P.134
- “Cleaning inside the printer” P.136
- “Emptying waste ink tank” P.138
- “Cleaning of the parts around the print head” P.141
- “Soak Cleaning” P.145
- “Clean the color sensor” P.150
- “Replace the flushing box pad” P.152
- “Replace the Cleaning Wiper” P.158

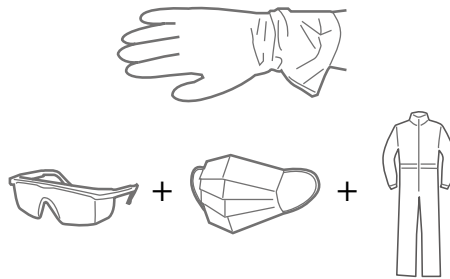

About CR Maintenance

CR maintenance menu allows you to move the carriage to be able to perform maintenance.

Use this menu to perform the following maintenance;

- “Cleaning of the cleaning wiper” P.132
- “Cleaning of the parts around the capping unit” P.134
- “Cleaning of the parts around the print head” P.141
- “Clean the color sensor” P.150
- “Replace the Cutter” P.155
- “Replace the Cleaning Wiper” P.158

1 Tap [**>**] key while [**Print Ready**] is displayed on the panel.

2 Use [**^**] / [**V**] key to select [**CR Maintenance Start —> Enter**].

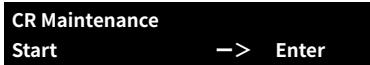

CR Maintenance
Start —> Enter

Note

You can also select this from the setup menu of the printer control panel.

1. Tap [**Home**] key.
2. Use [**V**] key to select [**Menu2 Maintenance**] and tap [**>**] key.
 - [**Maintenance1 Cleaning [Short]**] appears.
3. Use [**^**] / [**V**] key to select [**Maintenance4 Other Maintenance**] and tap [**>**] key.
 - [**Maintenance1 CR Maintenance**] appears.
4. Tap [**>**] key.
 - [**CR Maintenance Start —> Enter**] appears.

3 Tap [**Enter**] key to start maintenance.

- The carriage moves to the left maintenance space.
- The wiper moves to the maintenance position.
- [**CR Maintenance End —> Enter**] appears.

4 Open the covers and perform a maintenance.

- If the cover is open for more than ten minutes, [**Close the Cover**] will be displayed.

Note

Tapping [**V**] key will drive the suction pump to suck waste fluids in the capping unit.

5 Once maintenance is complete, close all the covers.

6 Tap [**Enter**] key to end the maintenance.

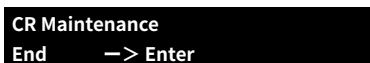

CR Maintenance
End —> Enter

Regular Maintenance

Cleaning of the cleaning wiper

! Make sure to read the following sections before this maintenance.

- “About Maintenance” P.16
- “Ink and waste fluid” P.17

Important!

Follow these precautions when cleaning:

- If dirt is difficult to remove, perform a cleaning [**Short**] before this cleaning.
- Use a dry cleaning stick. Wet cleaning stick causes print head malfunction.
- Do not touch the tip of cleaning stick with finger. Finger oil may cause print head malfunction.
- Do not reuse the cleaning stick. Dust and other particles may adhere to the print head, causing it to malfunction.
- The standard maintenance time is about five minutes. If it takes longer, the print head will get dried, causing the damage.

1 Prepare the necessary items for maintenance.

What you need:

- Polyethylene gloves, protective goggles, protective mask
- Cleaning stick

2 Wear protective equipment.

→ “Wearing protective equipment” P.130

3 Put the printer into CR Maintenance state.

→ “About CR Maintenance” P.131

4 Open the front cover.

5 Open the maintenance cover on the right side.

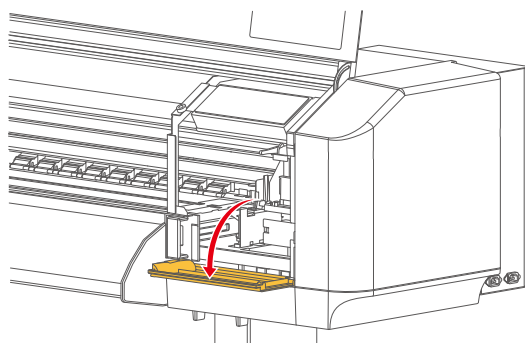

- 6** Use the cleaning stick to remove ink or dust sticking to the cleaning wiper. Wipe off on the left side (①) and right side (②) of the cleaning wiper.

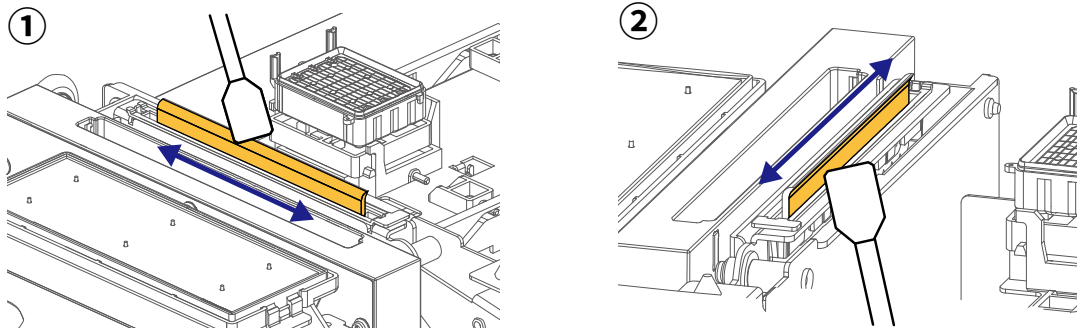

- 7** Close the maintenance cover on the right side.

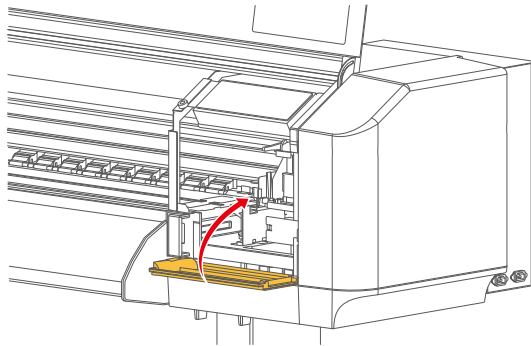

- 8** Close the front cover.

- 9** Tap **[Enter]** key to end the maintenance.

```
CR Maintenance
End    -> Enter
```

- 10** Tap **[Home]** key to end the procedure.

```
CR Maintenance
Start  -> Enter
```

Note

Put the used cleaning stick in a plastic bag and dispose of it according to the local regulations.

Cleaning of the parts around the capping unit

! Make sure to read the following sections before this maintenance.

→ “About Maintenance” P.16

→ “Ink and waste fluid” P.17

Important!

Follow these precautions when cleaning:

- If dirt is difficult to remove, perform a cleaning [**Short**] before this cleaning.
- Use a dry cleaning stick. Wet cleaning stick causes print head malfunction.
- Do not touch the tip of cleaning stick with finger. Finger oil may cause print head malfunction.
- Do not reuse the cleaning stick. Dust and other particles may adhere to the print head, causing it to malfunction.
- The standard maintenance time is about five minutes. If it takes longer, the print head will get dried, causing the damage.

1 Prepare the necessary items for maintenance.

What you need:

- Polyethylene gloves, protective goggles, protective mask, protective clothing
- Cleaning stick

2 Wear protective equipment.

→ “Wearing protective equipment” P.130

3 Put the printer into CR Maintenance state.



→ “About CR Maintenance” P.131

4 Open the front cover.

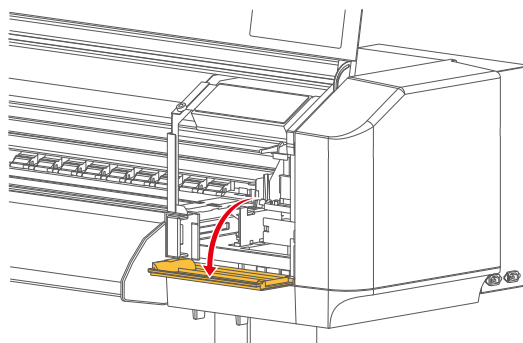
5 Open the maintenance cover on the right side.



6 Use the cleaning stick to clean around the rubber part of the capping unit to remove sticking ink and dust.

- : Clean this part
- : Absorbent material (**Never touch**)

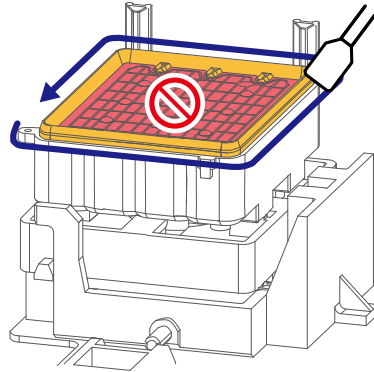

Important!

If dirt is difficult to remove, perform a cleaning [**Short**] before this cleaning.

7 Close the maintenance cover on the right side.

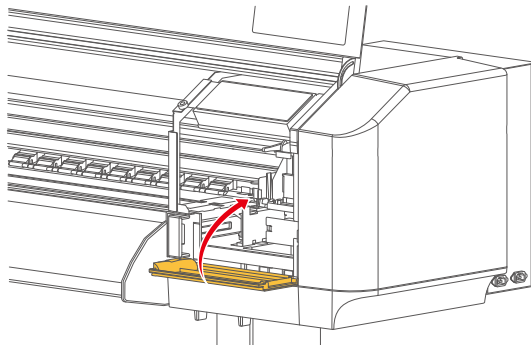

8 Close the front cover.

9 Tap [**Enter**] key to end the maintenance.

CR Maintenance
End → Enter

10 Tap [**Home**] key to end the procedure.

CR Maintenance
Start → Enter

Note

Put the used cleaning stick in a plastic bag and dispose of it according to the local regulations.

Cleaning inside the printer

! Make sure to read the following sections before this maintenance.

- “About Maintenance” P.16
- “Ink and waste fluid” P.17

! Caution

! When cleaning the inside of the printer, make sure to turn off the power and unplug the power cord from the wall outlet.

! Important!

Immediately after printing is finished, the printer heater gets hot. Touch the platen or media guide, and if it is hot, wait until it cools down.

1 Prepare the necessary items for maintenance.

What you need:

- Soft brush
- Paper towel or soft cloth
- Ethanol (Commercial product: more than 50% ethanol)
- Glove

2 Wear protective equipment.

→ “Wearing protective equipment” P.130

3 Remove media.

4 Turn off the printer.

→ “Turn off the printer” P.42

5 Unplug the power cord from the outlet.

6 Open the front cover.

- 7 Use a soft brush to clean the dust off the pressure rollers.

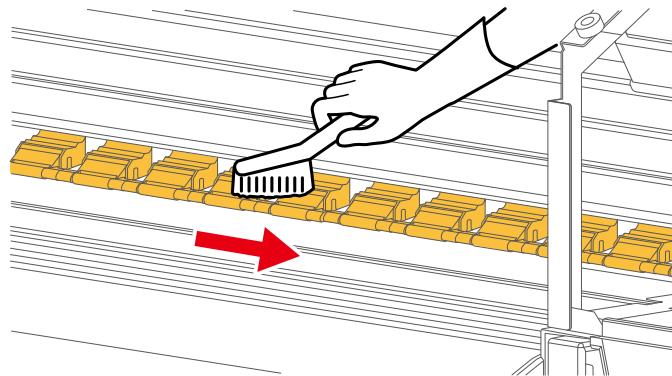

Important!

Do not use air duster to clean the dust inside the printer.
Dust may accumulate on the moving parts, leading to damage or noise.

- 8 Using a paper towel or soft cloth dampened with a small amount of ethanol, clean the platen, media guide and edge holders to remove dirt.

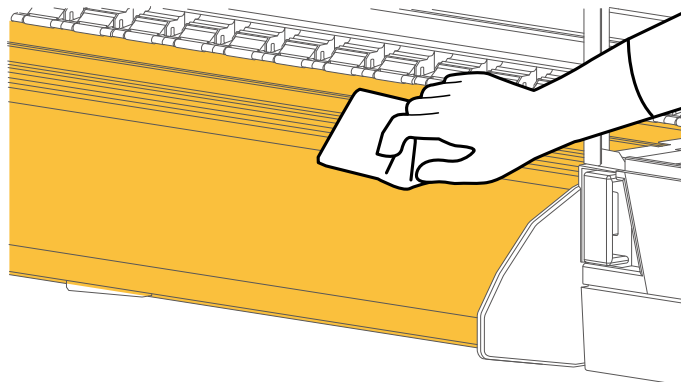

- 9 Close the front cover.

- 10 Plug the power cord to the wall outlet and turn on the printer.

→ **“Turn on the printer” P.39**

Emptying waste ink tank

! Make sure to read the following sections before this maintenance.

- “About Maintenance” P.16
- “Ink and waste fluid” P.17

In the following cases, drain waste fluids into a container to empty the waste ink tank;

- When the waste ink tank is more than half full before printing.
- When the following message appears on the panel.

Full WasteInkTank

→ (P.176)

Empty Waste Ink Tank
then Tap Enter

→ (P.175)

1 Prepare a container to collect waste fluid.

! Important!

The capacity of the waste ink tank is 2,000 ml. Make sure to prepare a container that has enough capacity to collect waste fluid.

2 Cover the floor under the waste ink tank with waste paper or cloth.

3 Wear protective equipment.

→ “Wearing protective equipment” P.130

4 Open the drain tube valve and drain waste fluid into an empty container.

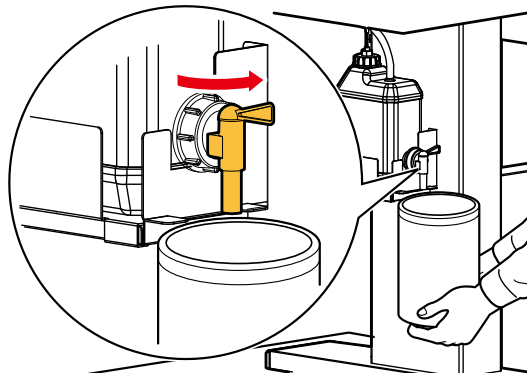

Important!

Waste fluid may splash while draining from the waste ink tank. Make sure to put the tip of the drain tube valve in the empty container and start draining.

5 Once you finish emptying the tank, close the drain tube valve firmly.

- Use a dry cloth to clean the tip of the drain tube valve.

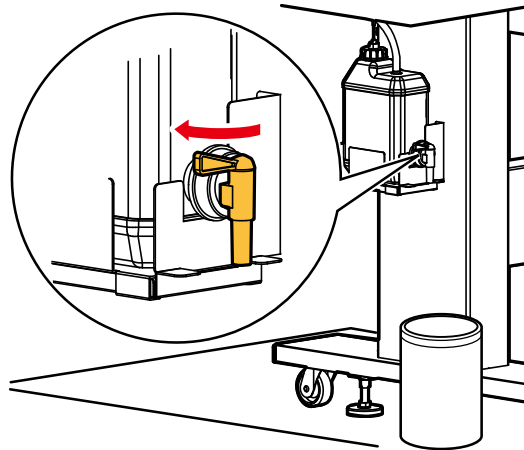
**6** Dispose of the waste fluids as industrial waste.

Maintenance based on your usage

When nozzle clogging occurred

Head cleaning

Run a head cleaning if you run a nozzle check before printing and the nozzles are clogged.

Important!

Even if you are not using a printer for more than one week, perform a head cleaning once a week.

- 1** Print a nozzle check pattern to check if all nozzles are firing ink properly.
→ [“Run a nozzle check” P.56](#)
- 2** If the nozzle is clogged, perform a head cleaning.
→ [“Perform a head cleaning” P.58](#)

Note

→ [“Nozzle clogging persists even after several head cleaning attempt” P.141](#)

Nozzle clogging persists even after several head cleaning attempt

If nozzle clogging persists even after repeated cleaning “Long” attempts, clean the parts around the print head (parts around the print head and cleaning wiper).

! Make sure to read the following sections before this maintenance.

→ [“About Maintenance” P.16](#)

→ [“Ink and waste fluid” P.17](#)

Important!

Follow these precautions when cleaning:

- If dirt is difficult to remove, perform a cleaning [**Short**] before this cleaning.
- Use a dry cleaning stick. Wet cleaning stick causes print head malfunction.
- Do not touch the tip of cleaning stick with finger. Finger oil may cause print head malfunction.
- Do not reuse the cleaning stick. Dust and other particles may adhere to the print head, causing it to malfunction.
- The standard maintenance time is about five minutes. If it takes longer, the print head will get dried, causing the damage.

Cleaning of the parts around the print head

1 Prepare the necessary items for maintenance.

What you need:

- Polyethylene gloves, protective goggles, protective mask
- Cleaning stick

2 Wear protective equipment.

→ [“Wearing protective equipment” P.130](#)

3 Put the printer into CR Maintenance state.

→ [“About CR Maintenance” P.131](#)

4 Open the front cover.

5 Open the maintenance cover on the left side.

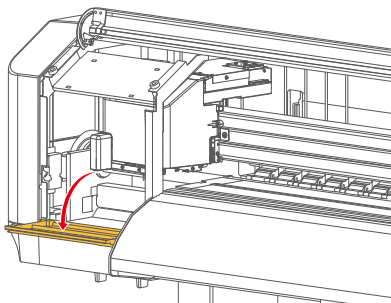

6 Use a cleaning stick to remove ink or dust sticking to the parts around the print head.

- Clean this part
 - Print head guide (①)
 - Gap between the print head guide and bottom of the carriage (②)
 - Gap between the print head guide and the print head (③)
- Nozzle surface (**Never touch**)

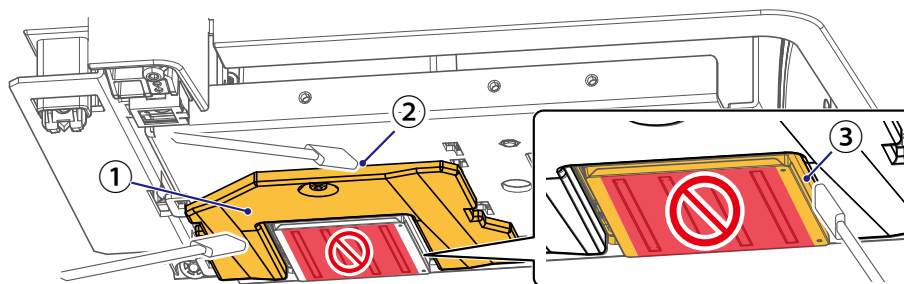

7 Open the maintenance cover on the right side.

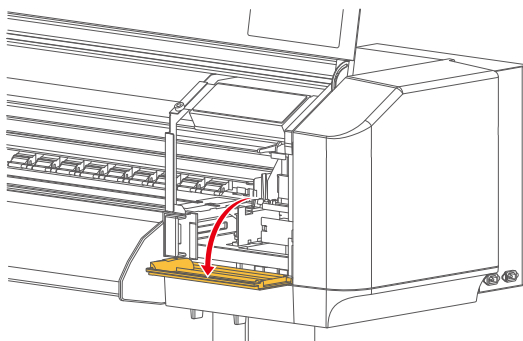

- 8** Use the cleaning stick to remove ink or dust sticking to the cleaning wiper.
Wipe off on the left side (①) and right side (②) of the cleaning wiper.

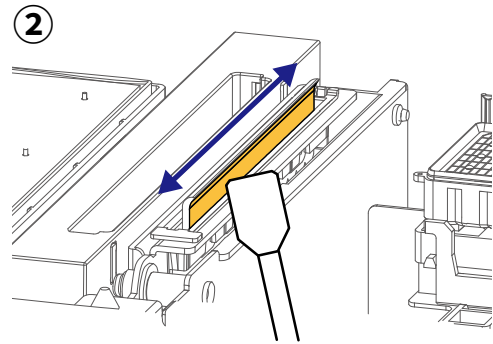
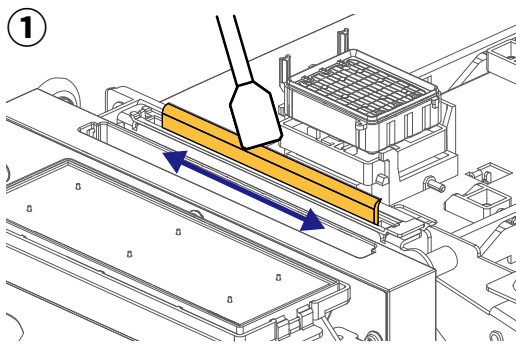

- 9** Close the left and right sides of maintenance covers.

- 10** Close the front cover.

- 11** Tap **[Enter]** key to end the maintenance.

```
CR Maintenance
End    -> Enter
```

- 12** Tap **[Home]** key to end the procedure.

```
CR Maintenance
Start  -> Enter
```

Note

Put the used cleaning stick in a plastic bag and dispose of it according to the local regulations.

Note

If the nozzle clogging still persists even after cleaning the parts around the print head (parts around the print head and cleaning wiper), perform a “Little Charge” cleaning.

→ **“If severe nozzle clogging occurred” P.144**

If severe nozzle clogging occurred

Little Charge

Gives higher cleaning efficiency than cleaning “Long”, but consumes a lot of ink. Follow the precautions when performing.

Caution

When performing Little Charge and Initial Charge, observe the followings.

If ink charging is interrupted, it may consume more ink to do the ink charging again.

- Do not turn off the power.
- Do not unplug the power cord.
- Do not open the front cover or maintenance cover.
- Do not raise the pressure rollers.
- Do not remove the ink bag case or smartchip card.
- Do not use ink bags with low ink levels.

1 Tap **[Home]** key.

2 Go to the “Little Charge” menu.

Menu flow

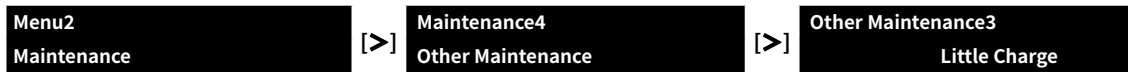

- **[▲]** / **[▼]** key: Select a menu item.
- **[>]** key: Enter the menu.

3 Tap **[Enter]** to start a Little Charge.

Ink Refill **%

Once Little Charge is finished, **[Print Ready]** will appear.

Note

If nozzle clogging persists even after repeated “Little Charge” two or three times, perform a “Soak Cleaning”.

→ [“Soak Cleaning” P.145](#)

Soak Cleaning

Soak the print head in the maintenance cleaning solution filled in the head cap to clean dirt off the nozzle surface.

! Make sure to read the following sections before this maintenance.

→ “About Maintenance” P.16

→ “Ink and waste fluid” P.17

1 Prepare the necessary items for maintenance.

What you need:

- Polyethylene gloves, protective goggles, protective mask
- Dropper
- Designated maintenance cleaning solution

2 Wear protective equipment.

→ “Wearing protective equipment” P.130

3 Tap [➤] key while [Print Ready] is displayed on the panel.

4 Use [▲] / [▼] key to select [Soak Cleaning Start → Enter].



Soak Cleaning
Start → Enter

Note

You can also perform the “Soak Cleaning” menu from the setup menu of the printer control panel.

1. Tap [Home] key.
2. Use [▼] key to select [Menu2 Maintenance] and tap [➤] key.
 - [Maintenance1 Cleaning [Short]] appears.
3. Use [▲] / [▼] key to select [Maintenance4 Other Maintenance] and tap [➤] key.
 - [Maintenance1 CR Maintenance] appears.
4. Use [▼] key to select [Maintenance2 Soak Cleaning] and tap [➤] key.
 - [Soak Cleaning Start → Enter] appears.

- 5 Tap **[Enter]** key to start maintenance.
 - a. The carriage moves to the left maintenance space.
 - b. **[Pour Cleaning fluid End → Enter]** appears.

Important!

Soak cleaning cannot be performed when the printer is in the following conditions.

- Front cover or maintenance cover is open
- Waste ink tank is full.
- Ink bag case is removed
- Smart chip card is removed.
- A non-genuine smart chip card is inserted.

- 6 Open the front cover.

- 7 Open the maintenance cover on the right side.

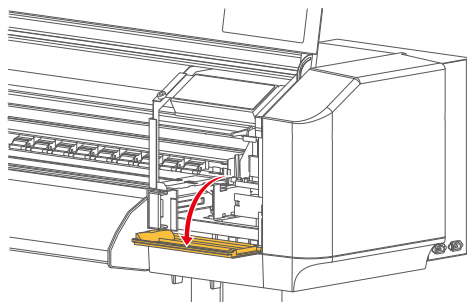

- 8 Fill the head cap with maintenance cleaning solution.

Use a dropper to fill it with maintenance cleaning solution until the cleaning solution almost overflows the cap.

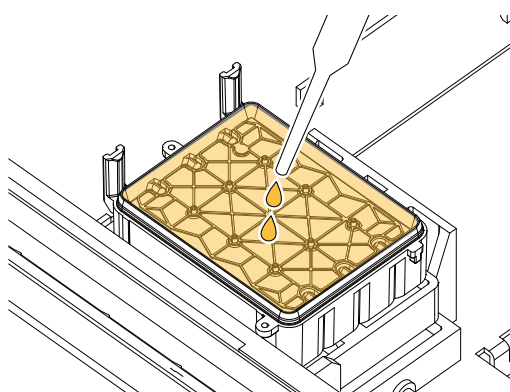

- 9** Using a paper towel, wipe off any ink on the surface of the air valve (parts ① and ②).

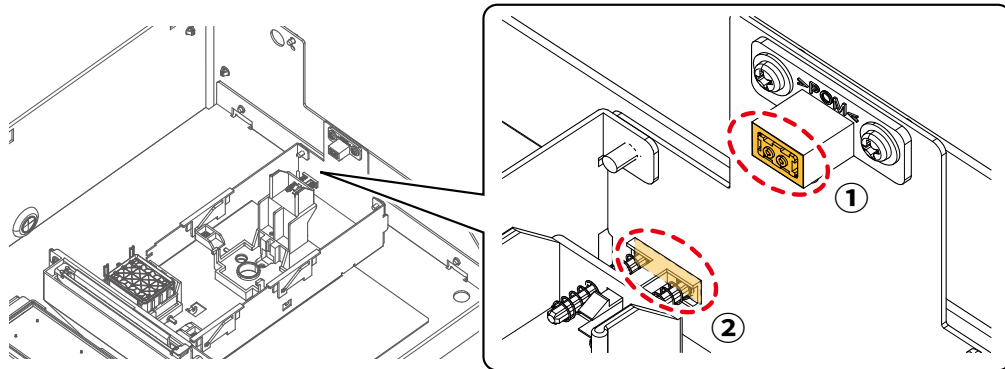

- 10** Tap **[Enter]** key.

- The carriage returns to the home position.

Pour Cleaning fluid
End → Enter

- 11** Use **[^]** / **[V]** key to specify a soaking time and tap **[Enter]** key.

- 10 minutes is recommended for soak cleaning time.
- The countdown begins. When the soak cleaning timer reaches zero, the suction begins followed by cleaning. (Or suction only if cleaning cannot be performed)

Soaking time
(1-99) 10 min

- 12** End the soak cleaning.

Wipe the maintenance cleaning solution on the dropper with a paper towel.

Note

Please keep the bottle lid of the designated maintenance cleaning solution tightly closed.

Note

If nozzle clogging persists even after “Soak Cleaning”, you can select the nozzles which fire properly.

→ **“Select Nozzle” P.148**

Select Nozzle

You can select active nozzles for printing. Select this menu if there are clogged nozzles. Print a confirmation pattern and select the pattern that has no missing lines.

Step1. Print a confirmation pattern.

1 Tap **[Home]** key.

2 Access the “Select Nozzle” menu.

Menu flow



- **[▲]** / **[▼]** key: Select a menu item.
- **[>]** key: Enter the menu.

3 Tap **[>]** key.

4 Use **[▲]** / **[▼]** key to select **[Print]** and tap **[Enter]** key.

- The printer begins printing a confirmation pattern.
- Check the printed results to find the pattern with no missing lines. In the example of illustration below, the patterns A, B, D and E do not have nozzle clogging.

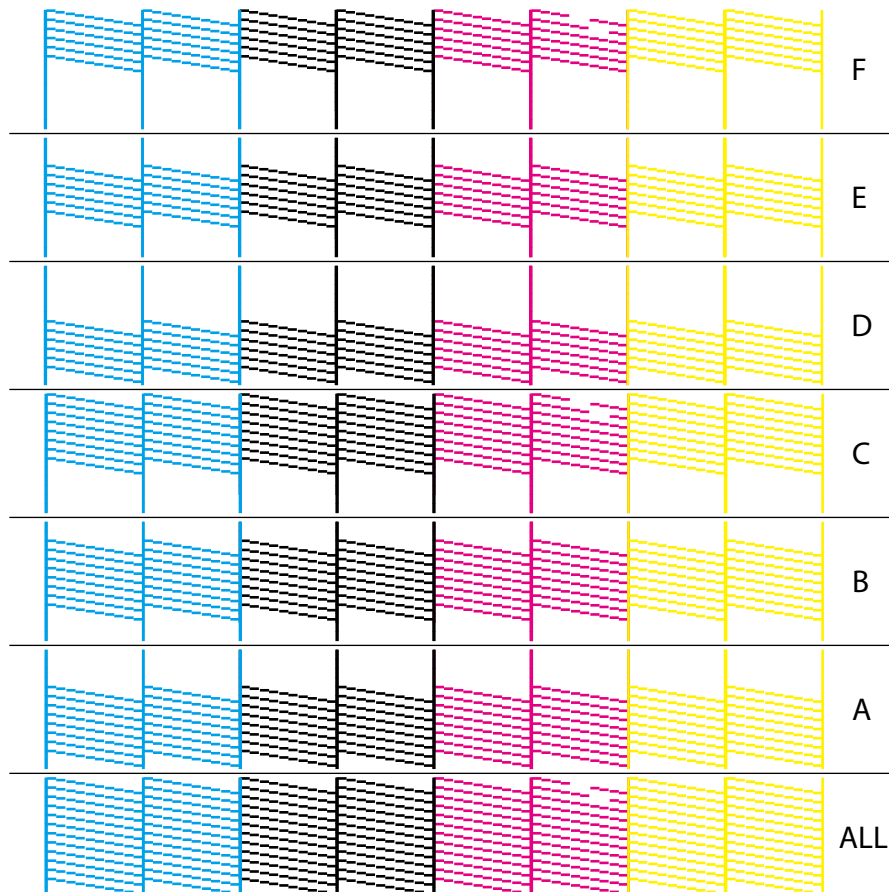

Step2. Select nozzles.

1 Access the “Select Nozzle” menu.

Menu flow

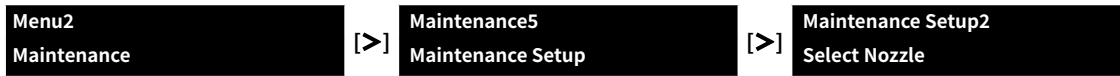

- [▲] / [▼] key: Select a menu item.
- [>] key: Enter the menu.

2 Tap [>] key.

3 Use [▲] / [▼] key to select **[Nozzle Area Select]** and tap [>] key.

Use [▲] / [▼] key to select the pattern with no missing lines and tap **[Enter]** key.

Note

- If there are more than one pattern that do not suffer from nozzle clogging, select the one that has more number of active nozzles. In descending order of active nozzles: ALL > A = B = C > D = E = F. If the patterns A and D are selectable, you should select the pattern A.
- The MPS function will be disabled when the Nozzle Area Select menu is enabled.

When auto adjustment fails repeatedly in the Adjust Print calibration.

Clean the color sensor

! Make sure to read the following sections before this maintenance.

→ [“About Maintenance” P.16](#)

→ [“Ink and waste fluid” P.17](#)

! Important!

Follow these precautions when cleaning:

- Do not push hard on the color sensor glass with cleaning stick. This will cause damage to the glass.
- Do not reuse the cleaning stick. Dust may adhere to the color sensor, causing it to malfunction.
- The standard maintenance time is about five minutes. If it takes longer, the print head will get dried, causing the damage.

1 Prepare the necessary items for maintenance.

What you need:

- Polyethylene gloves, protective goggles, protective mask
- Cleaning stick
- Ethanol (Commercial product: more than 50% ethanol)

2 Wear protective equipment.

→ [“Wearing protective equipment” P.130](#)

3 Put the printer into CR Maintenance state.

→ [“About CR Maintenance” P.131](#)

4 Open the front cover.

5 Open the maintenance cover on the left side.

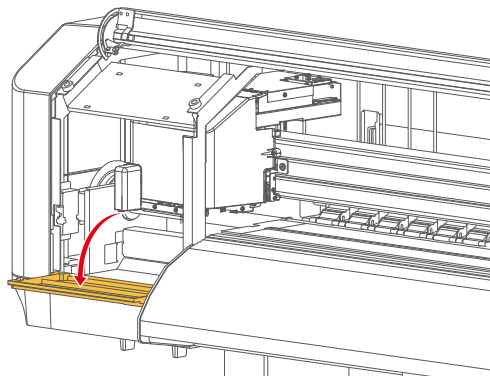

6 Clean the glass surface of the color sensor on the bottom of the carriage to remove ink and dust.

Use a cleaning stick dampened with a small amount of ethanol.

- : Clean this part (Do not push hard on glass surface)
- : Nozzle surface (Never touch)

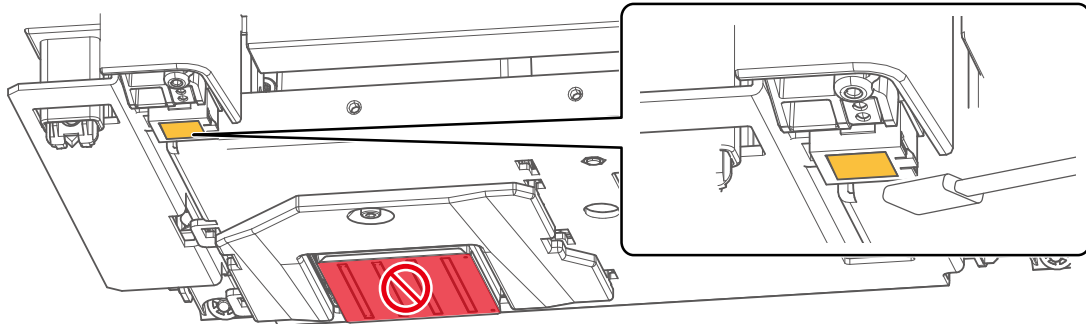

7 Close the left side of maintenance covers.

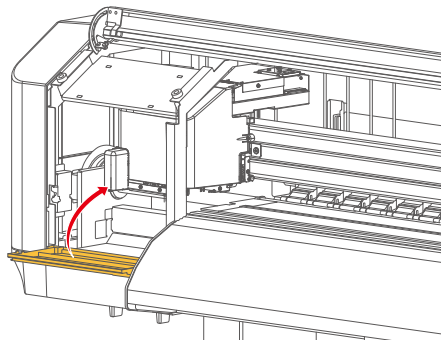

8 Close the front cover.

9 Tap [Enter] key to end the maintenance.

```
CR Maintenance
End    -> Enter
```

10 Tap [Home] key to end the procedure.

```
CR Maintenance
Start  -> Enter
```

Note

Put the used cleaning stick in a plastic bag and dispose of it according to the local regulations.

Important!

If problem persists, please contact your local MUTOH dealer.

Replace the consumable parts

Replace the flushing box pad

Flushing box is a part to collect waste fluids from the print head.

Replace the flushing box pad periodically. Continued use without replacement will cause damage to the print head.

! Make sure to read the following sections before this maintenance.

→ “About Maintenance” P.16

→ “Ink and waste fluid” P.17

Step1. Checking steps

- 1 Open the front cover.
- 2 Open the maintenance cover on the right side.

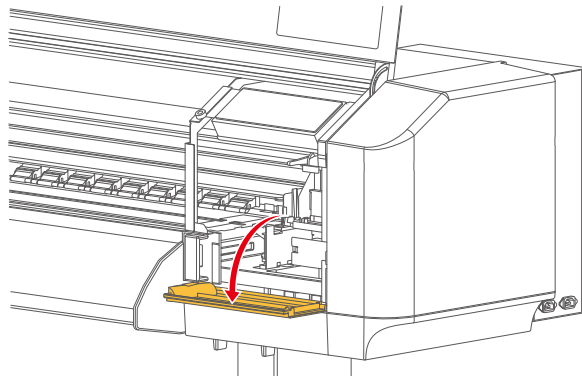

- 3 Check the flushing box pad.
 - (When looking from the side) if the ink deposits accumulated on the flushing pad is visible through the flushing box frame, you need to replace it.

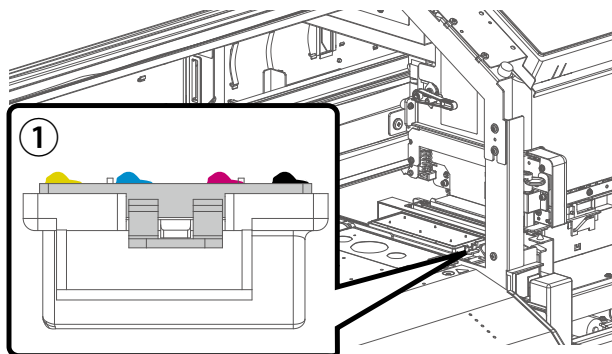

- 4 Close the maintenance cover on the right side.

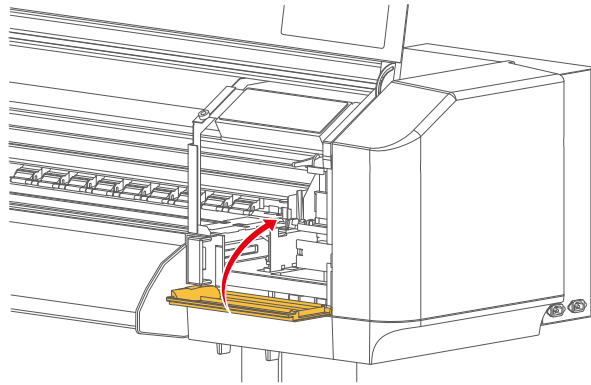

- 5 Close the front cover.

Step2. Replacing steps

- 1 Prepare the necessary items for maintenance.

What you need:

- Polyethylene gloves, protective goggles, protective mask
- Flushing box pad
- Waste paper (paper that ink does not bleed through)

- 2 Wear protective equipment.

- 3 Open the front cover.

- 4 Open the maintenance cover on the right side.

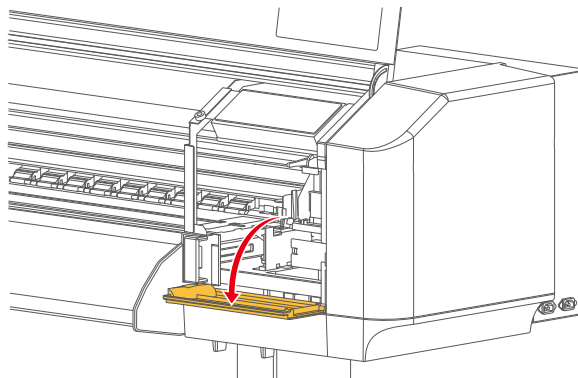

- 5 Cover the platen with the waste paper.

Important!

Ink may drip from the flushing box pad. We recommend covering the floor with paper as well.

- 6 Lift the tab on the flushing box pad to unhook the box and remove the pad.

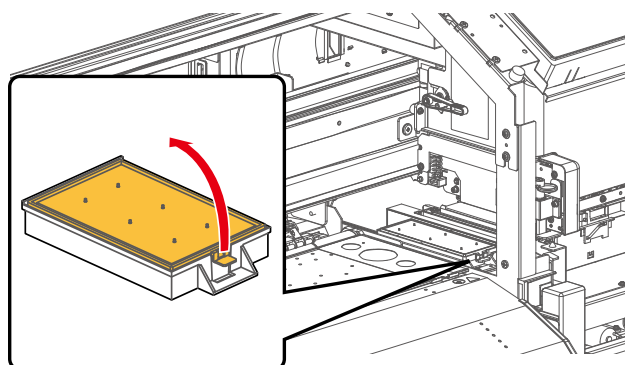

Important!

When removing the flushing box pad, be careful of ink dripping.

Note

Put the used flushing box pad in a plastic bag and dispose of it according to the local regulations.

- 7 Attach a new flushing box pad.

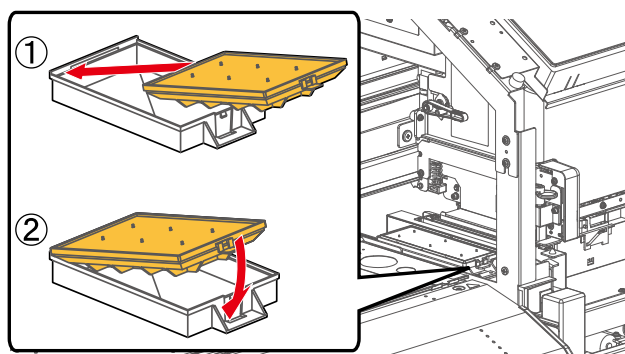

- 8 Close the maintenance cover on the right side.

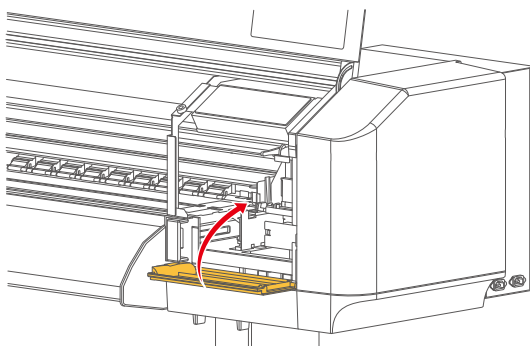

- 9 Close the front cover.

Replace the Cutter

Caution

-  Do not push the tab on the cutter holder too hard or release suddenly.
There is a spring under the cutter so that the cutter may jump out from the holder.
- Do not touch the cutter blade.
It may cause injury.

1 Prepare the necessary items for maintenance.

What you need:

- Replacement cutter blade

2 Put the printer into CR Maintenance state.

→ [“About CR Maintenance” P.131](#)

3 Open the front cover.

4 Open the maintenance cover on the left side.

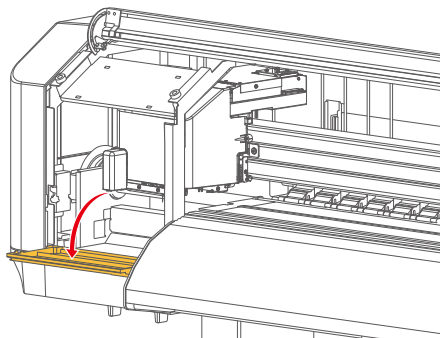

5 While lightly pushing the tab on the cutter, rotate the cutter cap in the direction shown in the illustration.

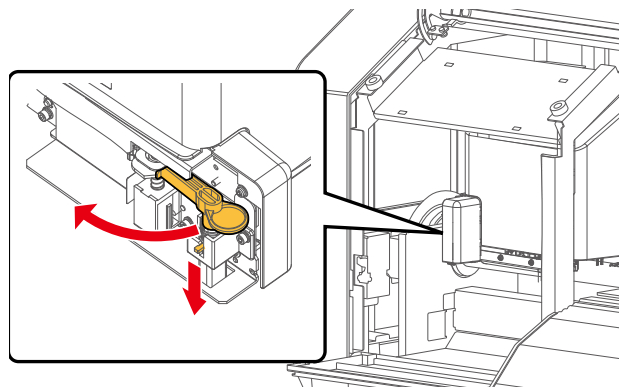

Important!

Do not push down the cutter cap.
This could damage the cap.

6 Remove the cutter.

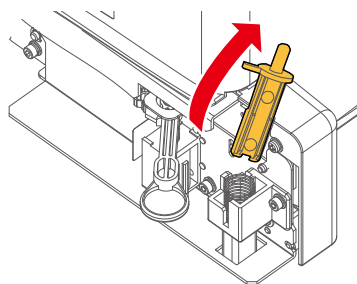

Note

Put the used cutter in a plastic bag and dispose of it according to the local regulations.

7 Install a new cutter.

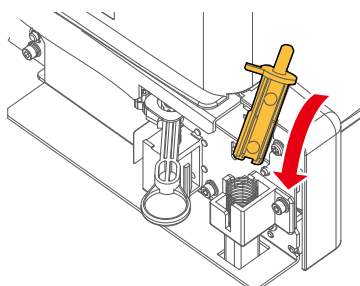

8 While lightly pushing the tab on the cutter, put the cutter cap back to its original position.

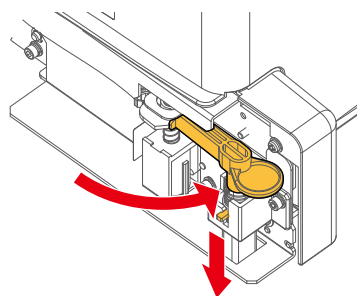

9 Close the left side of maintenance covers.

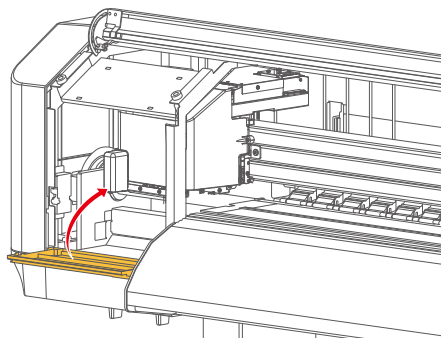

10 Close the front cover.

11 Tap **[Enter]** key to end the maintenance.

```
CR Maintenance
End    -> Enter
```

12 Tap **[Home]** key to end the procedure.

```
CR Maintenance
Start  -> Enter
```

Replace the Cleaning Wiper

! Make sure to read the following sections before this maintenance.

- “About Maintenance” P.16
- “Ink and waste fluid” P.17

Important!

- This printer has two types of cleaning wipers (black / gray).
- There are appropriate combination of print head height and cleaning wiper (See below). Proper cleaning cannot be carried out with incorrect combination. When changing the print head height, check the combination and replace with an appropriate cleaning wiper if needed.
- In the factory default, the black cleaning wiper is installed.

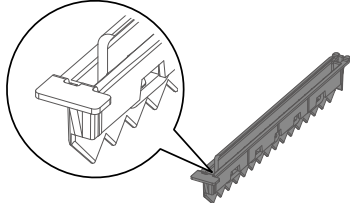
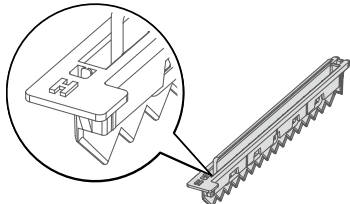
Print head height	Types of cleaning wiper
For “Low1”, “Low2”, “Middle”	Black (installed in the printer when shipped) 
For “High”	Gray (bundled in the printer box) 

1 Prepare the necessary items for maintenance.

What you need:

- Polyethylene gloves, protective goggles, protective mask
- Replacement cleaning wiper
- Waste paper (paper that ink does not bleed through)

2 Wear protective equipment.

3 Put the printer into CR Maintenance state.

→ “About CR Maintenance” P.131

4 Open the front cover.

- 5** Open the maintenance cover on the right side.

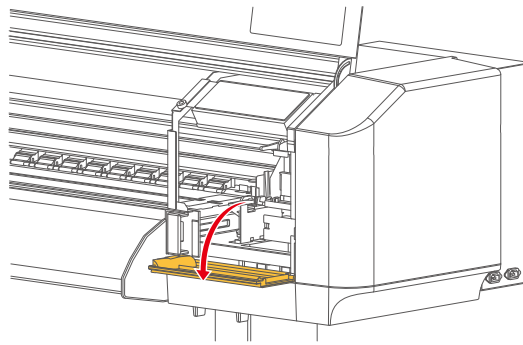

- 6** Cover the platen with the waste paper.

Important!

Ink may drip from the cleaning wiper. We recommend covering the floor with paper as well.

- 7** Remove the cleaning wiper.

- a. Slide the hook on the wiper to the back to unhook from the wiper slot.
- b. Lift the hook and remove the cleaning wiper.

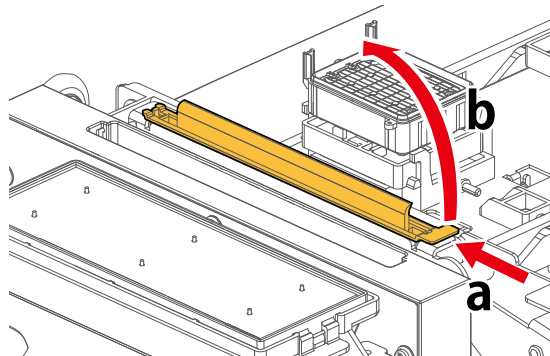

Important!

When removing the cleaning wiper, be careful of ink dripping.

Note

Put the used cleaning wiper in a plastic bag and dispose of it according to the local regulations.

- 8** Replace with an appropriate cleaning wiper depending on the print head height.
- Slide the back side of the new cleaning wiper into its slot.
 - Push the wiper hook down until it clicks into place.

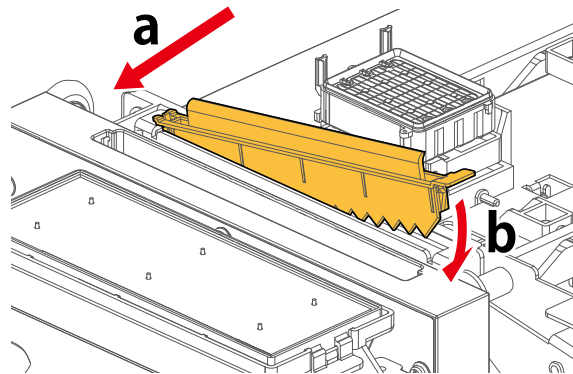

Important!

Do not touch the rubber part of the cleaning wiper with bare hands. Finger oil may cause print head malfunction.

- 9** Close the maintenance cover on the right side.

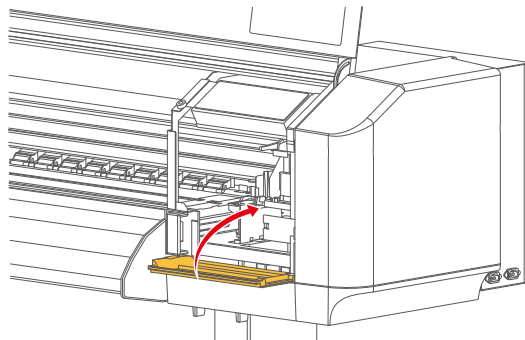

- 10** Close the front cover.

- 11** Tap **[Enter]** key to end the maintenance.

```
CR Maintenance
End    -> Enter
```

- 12** Tap **[Home]** key to end the procedure.

```
CR Maintenance
Start  ->  Enter
```

Moving or transporting the printer

Moving the printer

This section explains how to move this product.

Important!

- Empty the waste ink tank even when moving for a short distance. Failure to do so may result in damage to the printer.
- Keep the product level and move it with at least three people. Otherwise proper operation cannot be guaranteed.
- Wearing safety shoes is recommended for moving this product.

Preparation for moving the printer

- 1 Turn off the printer.
→ [“Turn off the printer” P.42](#)
- 2 Empty the waste ink tank.
→ [“Emptying waste ink tank” P.138](#)
- 3 Remove all the cables including the power cord.
- 4 Loosen the four adjusters of the stand by rotating them to the direction shown in the illustration.

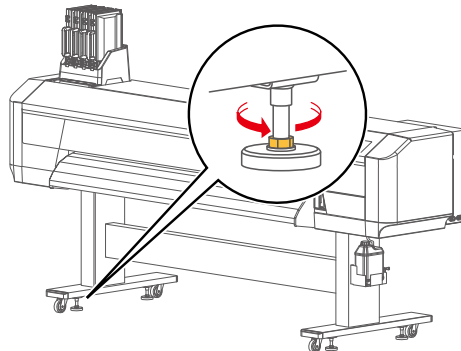

- 5 Move the printer.
→ [“Installation after moving” P.162](#)

Installation after moving

- 1 Select a suitable location for installation.
→ **“Check before installation” in the Startup Guide**
- 2 After moving the printer to the installation site, use the adjusters to lock the printer.
- 3 Connect the cables including the power cord.
- 4 Turn on the printer.
→ **“Turn on the printer” P.39**
- 5 Run a nozzle check to make sure all nozzles are clear.
→ **“Nozzle check and head cleaning” P.56**
- 6 Perform an Adjust Print calibration.
→ **“Adjust Print” P.94**

Transporting the printer

When transporting this product, it must be repacked in the original packaging and packaging materials as you purchased to protect the printer from vibration and shock.

 **Important!**

When transporting this product, please consult your local MUTOH dealer.

Long-term storage

When the printer is not in use for an extended period of time, perform this cleaning to flush ink out of the printer for storage.

Flushing ink

- 1 Prepare the necessary items for long-term storage.

What you need:

- Cleaning bag: x4

- 2 Tap **[Home]** key.

- 3 Access the “Longstore” menu.

Menu flow

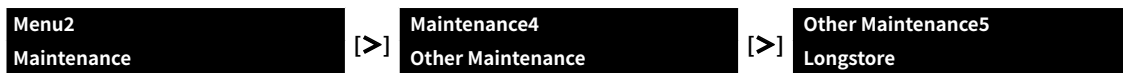

- **[▲]** / **[▼]** key: Select a menu item.
- **[>]** key: Enter the menu.

- 4 Tap **[>]** key.

- 5 Tap **[Enter]** key to begin the task.



- 6 Use **[▲]** / **[▼]** key to select **[Prepare Cleaning Bag Yes]** and tap **[Enter]** key.

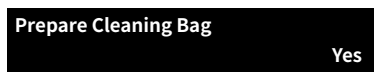

The following will appear.



- 7 Empty the waste ink tank and tap **[Enter]** key.

→ [“Emptying waste ink tank” P.138](#)

Note

Tapping **[Cancel]** key will cancel the “Longstore” menu.

- 8 Use [▲] / [▼] key to select **[Yes]** and tap **[Enter]** key.

Empty the Tank

Yes

The following will appear.

Remove Bags

- 9 Remove all ink bag cases and smartchip cards.

- a. Store the ink bags with the corresponding smartchip cards.

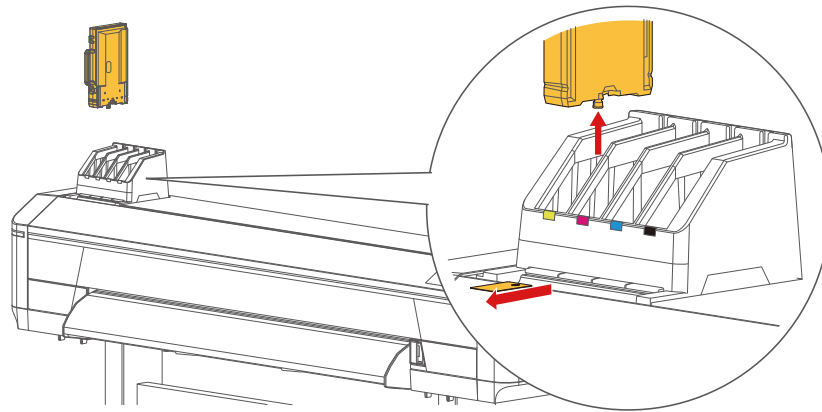

- b. Once all ink bag cases and smart chip cards are removed, the printer will begin flushing ink out of the printer.

Discharging

- c. Once flushing is done, the following will appear.

Insert Cleaning Bags

- 10 Place the cleaning bag in the ink bag case.

- a. Unlock four latches and open the ink bag case.

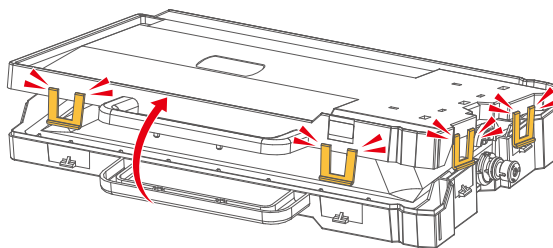

Important!

Do not apply excessive force when unlocking the latch. This will cause damage to the latch.

- b. Place the cleaning bag in the ink bag case.

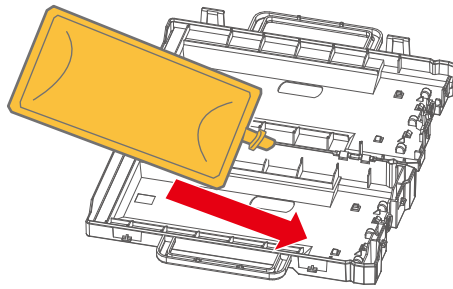

Note

Put the empty ink bag in a plastic bag and dispose of it according to the local regulations.

11 Close the ink bag case.

- a. Make sure that the spout of the cleaning bag is securely fitted into the groove.

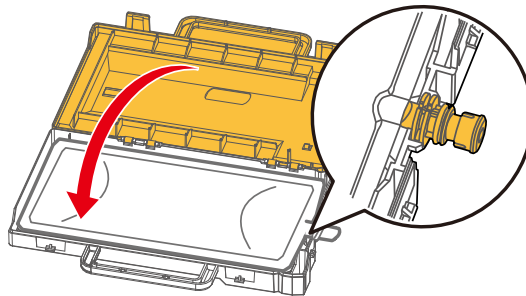

Important!

If not fitted, the printer cannot correctly detect the ink bag.

- b. Close the latches (x4) of the ink bag case properly.

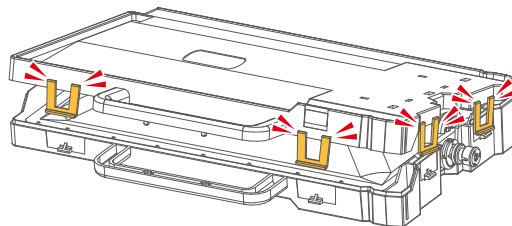

Important!

If not closed properly, it may cause ink leakage.

12 Insert the ink bag case and smartchip card into each slot.

- Face the latch side towards the front and insert the case into the slot. Make sure that they are fully inserted.

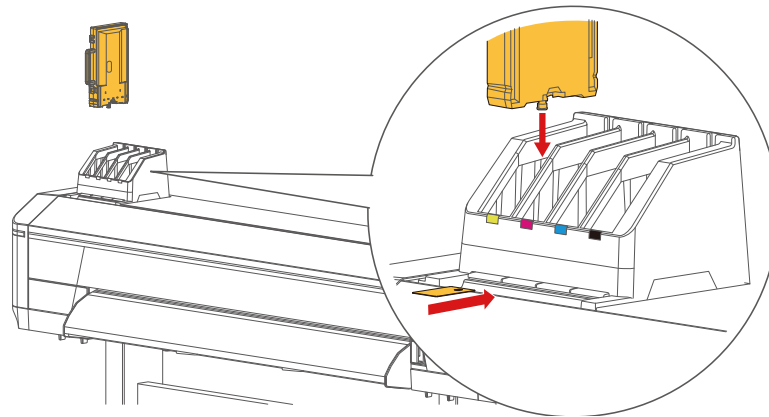

- Once all ink bag cases are loaded, the printer will begin flushing process.

Discharging

- Once cleaning solution is filled in the printer, the following will appear.

Remove Bags

13 Remove all ink bag cases and smartchip cards from each slot.

- Store the ink bags with the corresponding smartchip cards.

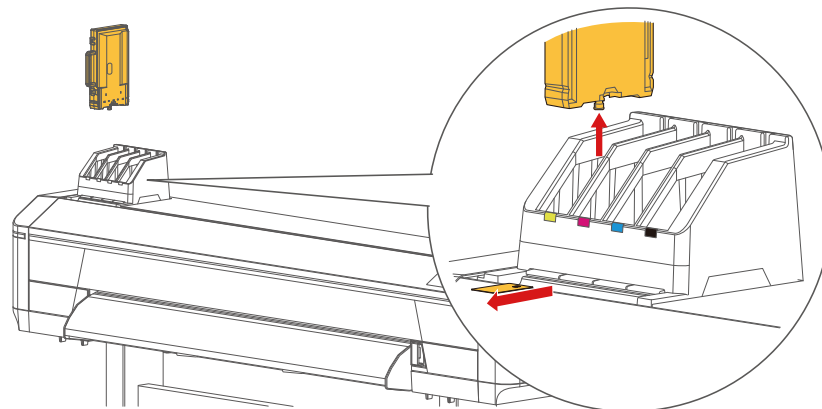

- Once all ink bag cases and smart chip cards are removed, the printer will begin flushing cleaning solution out of the printer.

Discharging

- Once flushing is done, **[Insert Cleaning Bags]** will appear.

Insert Cleaning Bags

14 Repeat the steps 9 to 12.

Once flushing is complete, **[[KCMY] Discharged]** will appear.

[[KCMY] Discharged]

15 Turn off the printer.

→ [“Turn off the printer” P.42](#)

 **Note**

→ [“Initial ink charging after Longstore cleaning” P.169](#)

Initial ink charging after Longstore cleaning

Caution

 Avoid the following actions when ink filling is in progress.

- Turn off the printer.
- Unplug the power cord of the printer.
- Open the front cover
- Open the maintenance cover.
- Raise the pressure rollers

1 Turn on the printer.

→ [“Turn on the printer” P.39](#)

2 Tap **[Enter]** key.

Ink Charge
Start → Enter

3 When **[Wash Retry? No]** appears, tap **[Enter]** key.

Wash Retry?
No

Note

If you need to perform a head cleaning, use **[V]** key to select **[Wash Retry? Yes]** and tap **[Enter]** key. Then follow the instructions on the printer control panel.

When flushing is complete, **[Insert Ink Bags]** will appear. Move to the next step.

The following message will appear.

Insert Ink Bags

4 Agitate ink in the new ink bag.

- Hold the ink bag with the ink outlet facing up and wait for three seconds.
- Invert it with the ink outlet facing down and wait for three seconds.
- Repeat this 3 times.

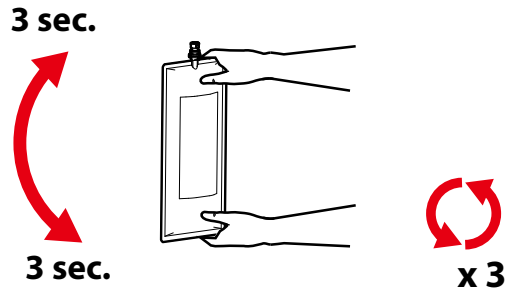

Important!

Make sure to replace with a new ink bag. If an ink bag does not have enough ink, it will run out of ink during initial ink charging and will consume more ink.

5 Place the ink bag in the ink bag case.

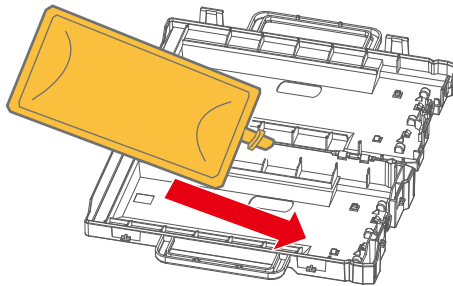

6 Close the ink bag case.

- Make sure that the spout of the ink bag is properly fitted into the groove in the case.

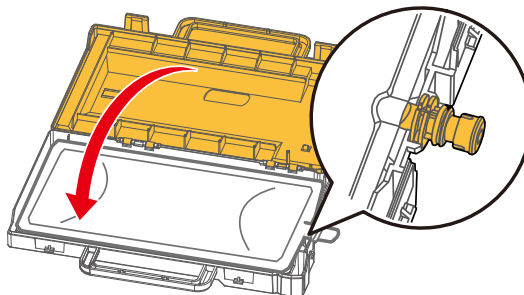

Important!

If not fitted, the printer cannot correctly detect the ink bag.

- b. Close the latches (x4) of the ink bag case properly.

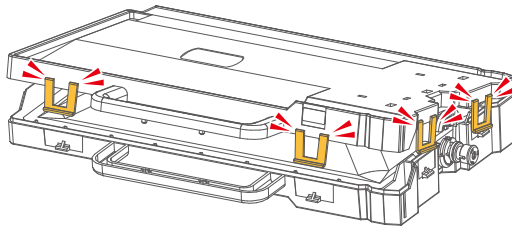

Important!

If not closed properly, it may cause ink leakage.

7 Insert the ink bag case and smartchip card into each slot.

- a. Make sure to match the color of the ink bag label with the color of the label attached to the ink slot.
- Face the latch side towards the front and insert the case into the slot.
 - Make sure that they are fully inserted.

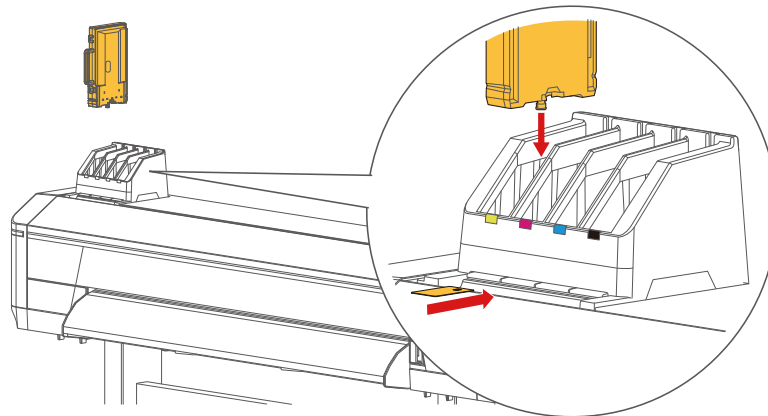

- b. Once all ink bag cases are loaded, ink charging will begin.

Ink Refill ** %

8 When ink charging is complete, **[Media End]** will be displayed.

Media End

 **Important!**

If you run a nozzle check print immediately after the initial ink charging, the following symptoms may occur.

- Printed lines are faded.
- Patterns are partially missing.

In such cases, perform “Little Charge” and then check the printed results. If the print result has no change even after Little Charge attempt, rest the printer for at least one hour and then perform a head cleaning or “Little Charge” cleaning again.

→ **“Little Charge” P.144**

If problem persists, please contact your local MUTOH dealer.

5 When problems occur

Messages and Error Messages 174

Troubleshooting 181

Messages and Error Messages

This section describes the messages that appear and solution to the messages

Status messages

This section describes the messages when the printer is working properly.

Display	Description
Print Ready	Ready-to-print state (Media is loaded)
Media End	Ready-to-print state (Media is not loaded). → “Load the media into the printer” P.43
Receiving	Data is being received.
Converting	Data is being converted.
Printing	Printing is in progress.
Remain: XXX.Xm	Displays the length remaining to print for the data currently being printed (unit: meter).
Remain Time: XXX.Xmin	Displays the time remaining to print for the data currently being printed (unit: minute).
Media Remain: XXXXm	Displays the remaining length of the media currently loaded (unit: meter).
Pausing Print Cancel Print —> Enter	Printing is being paused. • Tapping [Cancel] key will resume printing. • Tapping [Enter] will cancel printing.
Canceling	Printing is being canceled.
Feeding Forward	Feeding media forward.
Feeding Backward	Feeding media backward.
Warming Up	Heater is warming up.
Warming Up Skip —> Enter	To start printing before the heater warms up, tap [Enter] key.
Cleaning ** %	Cleaning is in progress. Please wait for a while.
Auto Nozzle Check	(Printer with an optional drop sensor unit installed) Automatic nozzle check is being performed. Please wait for a while.
Ink Refill ** %	Ink filling is in progress. Please wait for a while.
SubTank Refill ** %	Ink is being filled in the subtank. Please wait for a while.
Washing Head	Initial cleaning involves filling and draining cleaning solution. Or, the print head flushing is in progress in the head cleaning process. Please wait for a while.
Media: Type ** OK?	Initializing media. Please wait for a while. (** indicates the selected media type)
Media Initial	

Display	Description
Move To Origin Position	In the “Origin Setting” menu, the print head is moving to the print start position. Please wait for a while.
Confirm Position End —> Enter	The print head has moved to the print start position. Check the position and tap [Enter] key.
Power Off	The printer is being powered off. Please wait for a while.
Insert Ink Bags	Ink filling is in progress. Install the ink bag case.
Insert Cleaning Bags	Head cleaning is in progress. Install the cleaning bag.
Remove Bags	Head cleaning or ink discharging process is in progress. Remove the ink bag case.
Empty Waste Ink Tank then Tap Enter	The waste ink tank became full during initial ink charging. Empty the waste ink tank and tap [Enter] key.
S/C Reading	The smart chip card is being read.
*** Remote Mode *** End —> Enter	Remote panel mode is running through MSM. You cannot operate the printer control panel while in remote panel mode. Tapping [Enter] key will force quit the remote panel mode.
Roll Remain Error	The remaining roll media count has reached zero.(Printing stops)
Roll Near End: *** m	The remaining roll media count will soon reach zero. The remaining roll media is * m.
Life Times [Pump] OK —> Enter	The pump motor is nearing the end of its service life (the printer will continue to operate). Please contact your local MUTOH dealer.
Life Times [CR Motor] OK —> Enter	The CR motor is nearing the end of its service life (The printer will continue to operate). Please contact your local MUTOH dealer.
Life Times [PF Motor] OK —> Enter	The PF motor is nearing the end of its service life (The printer will continue to operate). Please contact your local MUTOH dealer.

Error message display and remedies

This section describes error messages and remedies.

These errors appear when some failure occurs during printer operation.

The printer displays the following error messages on the control panel and may stop operation.

Display	Description
Cover Open	Any or all of the covers (front cover, maintenance cover right, maintenance cover left) are open. Close the cover.
Use Lever to Lower Pressure Rollers	The pressure rollers are in up position. Lower the pressure rollers.
Load Media	No media is loaded. Load media. → “Load the media into the printer” P.43
Undefined Media	Media detection has failed. (The printer will stop operation) Load the media again.
Media Slant	Media skews. (The printer will stop operation) Load the media again.
Media Cut Error	Unable to cut media. (The printer will stop operation) Load the media again.
End of Roll	The printer is out of roll media. (The printer will stop operation) Load a new media. → “Load the media into the printer” P.43
Change Head Gap *** PG: **** W: **** mm	The print head height specified in the print data is different from the actual head height. Change the setting to the head height displayed. → “Print head height” P.61
[****] Ink End	Ink is out. (The printer will stop operation) Replace with a new ink bag. → “Replacing ink bag” P.85
[****] No Bag	Ink bag case is not inserted. (The printer will stop operation) Insert the ink bag case.
[****] No S/C Card	Smart chip card is not inserted. (The printer will continue to operate) Insert the smart chip card.
[****] S/C Ink Low	The ink become low. (The printer will continue to operate) Prepare a new ink bag for replacement.
[****] S/C Ink End	Smart chip card has run out of ink credit. (The printer will stop operation) Replace with a new ink bag. → “Replacing ink bag” P.85
[*] Chg. S/C Card	Replace with a new smart chip card.
[****] Discharged	Ink is not filled. Perform an initial ink charging. → “Initial ink charging after Longstore cleaning” P.169
Full WasteInkTank	The waste ink tank has become full. (The printer will stop operation) Immediately empty the tank. → “Emptying waste ink tank” P.138

Display	Description
[****] S/C ReadErr	Failed to read the smart chip card. Reinsert the smart chip card.
[****] S/C Col.Err	The ink bag case is installed in the wrong ink slot. Install the ink bag case in the correct ink slot.
[****] S/C Ink Err	This type of ink cannot be used for this product. Please contact your local MUTOH dealer.
[****] S/C CodeErr	An incorrect ink bag has been inserted. Please contact your local MUTOH dealer.
[****] Broken Chip	The smart chip card is damaged. Replace with a new ink bag. → “Replacing ink bag” P.85
Cannot Operate Outside Print Area	The printer is unable to print because there is not enough printable width on the media. Printable width on the media can be adjusted by changing CR origin (carriage moving direction) and side margin (left and right side margin) settings. → [Setup] P.115 > [Media Width] P.115 , [Origin] P.118 , [Side Margin] P.118 Printable width needed varies depending on the menu. Adjust the settings to secure enough width. → “Adjust Print” P.94(over 550 mm) → “Media feed adjustment” P.100(over 400 mm) → [Roll Length Manage] P.122 > [Print] P.122 , [Simple Print] P.122 (over 400 mm)
Cannot Operate Media Initial - Off	The printer is unable to display the “Roll Length Manage” menu because the “Media Initial” menu is set to [Off] . Set Media Initial to [Top&Width] or [Width] and then select the “Roll Length Manage” menu. → [Setup] P.115 > [Media Initial] P.115 → [Roll Length Manage] P.122
Cannot Operate No Media	No media is loaded. Load media. → “Load the media into the printer” P.43
Cannot Operate Roll Length - Off	The printer is unable to print because the “Roll Length” menu is set to [Off] . Specify the “Roll Length” menu settings first and then select the “Print” or “Simple Print” menu. → [Roll Length Manage] P.122 > [Roll Length] P.122 , [Print] P.122 , [Simple Print] P.122
Cannot Operate Output Mode - Take Up	The printer is unable to read the code when the “Output Mode” menu is set to [Take Up] . Set the “Output Mode” menu to [Off] and then select the “Scan” menu. → [Setup] P.115 > [Output Mode] P.115 → [Roll Length Manage] P.122 > [Scan] P.122

Display	Description
Auto Nozzle Check Nozzle Clog Present	<p>(Printer with an optional drop sensor unit installed)</p> <p>The printer ran an automatic cleaning cycle to recover blocked nozzles which had been detected by an auto nozzle check, but the nozzles are still clogged.</p> <p>→ “Automatic nozzle checking (when optional drop sensor unit is installed)” P.110</p> <p>Tapping [Enter] key will delete the message. Manually run a nozzle check and cleaning cycles.</p> <p>→ “Nozzle check and head cleaning” P.56</p>
Drop Sensor Failed Auto Nozzle Check Off	<p>(Printer with an optional drop sensor unit installed)</p> <p>Auto Nozzle Check is set to [Off] because the drop sensor is broken.</p> <p>→ “Automatic nozzle checking (when optional drop sensor unit is installed)” P.110</p> <p>Please contact your local MUTOH dealer.</p>
Temperature too low	<p>Printer’s temperature is too low. Adjust room temperature. Wait until the warning message is no longer displayed.</p> <p>→ “Specifications” P.193</p>
Temperature too high	<p>Printer’s temperature is too high. Adjust room temperature. Wait until the warning message is no longer displayed.</p> <p>→ “Specifications” P.193</p>

 **Note**

- [****] in [**Change Head Gap *****] will be replaced with either High, Middle, Low2 or Low1.
- [****] in the error message indicates the target ink bag of warning.
- When [**Ink End**] or [**No S/C Card**] and [**No Bag**] occur at the same time, the [**No Bag**] will be displayed in priority to other two errors.

Smartchip Recovery

When the following message is prompted on the control panel, a smartchip error such as broken chip may have occurred in the smartchip card.

When the following error message appears, check that the correct smartchip card is inserted and perform smartchip recovery. This will allow you to continue to print.

To perform smartchip recovery, do one of the followings according to the message appeared.

Display	Description
[*] S/C Recog. E	The smartchip card that needs smartchip recovery may have been installed. Remove the target smartchip card and insert it again. If the printer is still unable to read it, insert a new smartchip card. If [[*] Check Color OK → Enter] is displayed after reinserting the smart chip card, follow the instructions below.
[*] Check Color OK → Enter	The smartchip card that needs smartchip recovery may have been installed. Check that the correct smartchip card is inserted. <ul style="list-style-type: none"> • In case of wrong color insertion, insert a correct smartchip card. • If the correct smart chip card is inserted, tap [Enter] key. The printer will perform smartchip recovery and will continue to print.
[*] Chg. S/C Card	The smartchip card that the smartchip recovery was performed has run out of ink. Replace with a new smart chip card.

Note

- [*] in the error message indicates the target ink bag of warning.
- During smartchip recovery execution, the ink bag being recovered blinks in the ink status menu.
→ [“Ink Status” P.125](#)

Error requiring reboot

An error requiring reboot is displayed when the printer experiences a fatal failure in its operation, such as

- When an error that prevents the printer from driving occurred.
- When the electrical circuit (PCB, motor, sensor, etc.) of the printer is broken.
- When a failure in the printer control program occurred.

If an error requiring reboot occurs, the printer will stop operation after

1. the power of driving system is automatically shut down.
2. all the LED on the printer control panel blink, and the buzzer beeps repeatedly.
3. An error message appears in the printer control panel.

Tapping any key on the control panel will stop the beeps.

For an error requiring reboot, the printer will recover by removing the cause of the error and restarting the printer.

If the same error message appears again, please contact your local MUTOH dealer. When contacting us, please be sure to provide the code number of the error message.

Display	Description
E *** Err ○○○○○○○○○○ []	<p>A trouble that the error cannot be released has occurred.</p> <ol style="list-style-type: none"> 1. If there are any foreign materials such as torn paper adhering to the driving system, remove it. 2. Check that the part you replaced has been installed correctly. 3. Turn off the printer. Wait for a while and then restart the printer.

Important!

When an error requiring reboot occurs, you cannot turn off the printer from the setup menu in the control panel. Pressing the power button for more than 2 seconds will power off the printer.

Note

- [***] in the error message is the error code showing what type of error occurred.
- [] in the error message is the command code for the error occurred.

Troubleshooting

This section describes printer troubles that an error message is not prompted, and possible cause and solutions.

Note

- Printer status and error information can be checked from MSM status information.

If the printer is not working properly, please check MSM.

- Please use the latest version of MSM.

You can check the version information in MSM's help to see if there is a newer version than your MSM. If a newer version is available, download it from MUTOH Club.

→ **MUTOH Status Monitor Operation Manual**

Trouble during installation / initial setup

Printer does not work at all after powered on

- Check that the power cord is connected correctly.
- Does the AC power supply provide the specified voltage?

Connect to another outlet.

Cannot perform initial ink charging

- Is the sensor cable of the waste ink tank connected to the printer?

If the cable is not connected properly, the message [**Full WasteInkTank**] appears on the display. Connect it properly.

→ **“Attaching the waste ink tank” Startup Guide**

- Check that the front cover and maintenance covers are closed.
- Check that the pressure rollers are in down position.
- Make sure that ink bag cases and smartchip cards are all the way seated in the slots.

→ **“Loading a new ink bag” P.86**

Ink does not come out after initial ink charging.

- Check that the ink bag is not too cold.

Rest the ink bags for at least 3 hours at room temperature, and then perform head cleaning several times.

→ **“Perform a head cleaning” P.58**

- Is the power turned OFF during ink charging?

Turn the power ON and perform an initial ink charging again.

Nozzle clogging occurs after initial ink charging.

- Perform a head cleaning.
→ [“Perform a head cleaning” P.58](#)

If there is no improvement in the print result even after performing head cleaning, rest the printer for at least 1 hour. Then perform a head cleaning or Little Charge and run a nozzle check.

If the problem still persists, please contact your local MUTOH dealer.

Unable to connect to printer from MSM or RIP

- Check that the Ethernet cable is connected securely to the Ethernet port.
- Check that the network settings are configured correctly.
- Check that the printer’s network settings match with the computer’s settings.
→ [“Computer requirements” P.29](#)
→ [\[Setup\] P.115](#) > [\[Initial Settings\] P.119](#)

Media-related problems

Printer does not work even after media is loaded

- Check that the front cover and maintenance covers are closed.
- Check that the pressure rollers are in down position.
- Check that the media is loaded into the printer correctly.
 - **“Load the media into the printer” P.43**
- Check that the ink bag cases are correctly inserted into the ink slots.
- Do you use the printer within recommended environmental conditions?
 - Make sure to use the printer within the specification range.
 - **“Specifications” P.193**
- Is there any error message displayed on MSM?
 - Check the MSM status information.

Media removed, torn, or wrinkled during media initialization

- Check that the media is loaded into the printer correctly.
 - **“Load the media into the printer” P.43**
- Are there any foreign materials such as torn paper adhering to the pressure roller?
 - Clean the pressure roller.
 - **“Cleaning inside the printer” P.136**
- Do you use the printer within recommended environmental conditions?
 - Make sure to use the printer within the specification range.
 - **“Specifications” P.193**
- Are any curls or warps present on your media?
 - a. Place the edge holders on both edges of the media.
 - **“Step5. After loading the media” P.53**
 - b. Check that you select an appropriate vacuum fan setting.
 - **[Media Type] P.92 > [Vacuum Fan] P.93**
- Are there any folds, scratches, torn, winding curls or slacks on your roll media?
 - Replace the media.
- Is holddown pressure adequate for the roll media?
 - Try changing the pressure with the media feed lever or using the slide lock levers on the pressure rollers to individually reduce or cancel the pressurization.
 - **“Change pressure that comes onto entire media” P.65**
 - **“Change pressure of pressure rollers individually” P.66**

Printer does not detect media correctly

- Is the media skewed?
 - Load the media straight.
 - **“Load the media into the printer” P.43**

- Do you use the printer within recommended environmental conditions?

Make sure to use the printer within the specification range.

→ **“Specifications” P.193**

- Are you using media that has been printed before?

Use a new media.

Media jams occur frequently

- Do you use the printer within recommended environmental conditions?

Make sure to use the printer within the specification range.

→ **“Specifications” P.193**

- Are any curls or warps present on your media?

a. Place the edge holders on both edges of the media.

→ **“Step5. After loading the media” P.53**

b. Check that you select an appropriate vacuum fan setting.

→ **[Media Type] P.92 > [Vacuum Fan] P.93**

- Is the height of print head set appropriately for your media?

Check the height of print head.

→ **“Print head height” P.61**

- Are there any folds, scratches, torn, winding curls or slacks on your roll media?

Replace the media.

Media skews during printing

- Do you use the printer within recommended environmental conditions?

Make sure to use the printer within the specification range.

→ **“Specifications” P.193**

- Is the media skewed?

Load the media straight.

→ **“Load the media into the printer” P.43**

- Are any curls or warps present on your media?

a. Place the edge holders on both edges of the media.

→ **“Step5. After loading the media” P.53**

b. Check that you select an appropriate vacuum fan setting.

→ **[Media Type] P.92 > [Vacuum Fan] P.93**

- Are there any folds, scratches, torn, winding curls or slacks on your roll media?

Replace the media.

Note

Remove jammed or torn media according to **“Media is jammed” P.189**.

Printing problems

Data is sent but not printed

- Check that the Ethernet cable is connected securely to the Ethernet port.
- Is there any error message displayed on MSM?

Check the MSM status information.

Carriage pauses at either side of the printer during printing.

- Does your computer meet the following requirements?
 - OS: Windows 11
 - CPU: Intel (R) Core (TM) i5 or more
 - Memory: 16GB or more
 - Network: Use a Gigabit Ethernet-compatible network port and Gigabit Ethernet cable of Category 6 or higher.

Note

- The OS support period of MUTOH software follows the Microsoft support lifecycle policies.
- When using RIP software, please also check the system requirements of your RIP software.

- Are you using a Gigabit-capable Ethernet cable to connect to the printer?
Use a Gigabit-capable Ethernet cable of Category 6 or higher to connect the printer to the computer.
- Check the status of the MPS function.
 - **“Menus you can access while printing” P.81 > [MPS] P.82**
 - a. When set to **[On]**: Check that your computer (specification, CPU load), Ethernet cable (specification, connectivity) and network environment meet the requirements.
 - b. When set to **[Off]**: In MSM, the checkbox "MUTOH Print Server (MPS)" is unchecked or "MPS Optimization" is set to "Disable". Enabling the MPS function may resolve the problem.

Note

MPS function settings can be changed from MSM.

- Did you set waiting time in "Pass Wait"?
Set it to 0.0 (sec) again.
 - **[Setup] P.115 > [Print preferences] P.117 > [Pass Wait] P.118**

Media or print is smudged

- Are any curls or warps present on your media?
Place the edge holders on both edges of the media.
→ **“Step5. After loading the media” P.53**
- Check that you select an appropriate vacuum fan setting.
→ **[Media Type] P.92 > [Vacuum Fan] P.93**
- Is the media deformed by heat?
If the media is deformed by heat during standby, increase the feed amount from the “Start Feed” menu.
→ **[Setup] P.115 > [Start Feed] P.116**
- Does the media contain moisture or are you using the creased or wrinkled media?
Replace with a new media.
- Are the parts around the print head clean?
→ **“Cleaning of the parts around the print head” P.141**
- Is the height of print head set appropriately for your media?
Check the height of print head.
→ **“Print head height” P.61**

Printing position is incorrect or there are areas that are not printing

- Check that the media is loaded into the printer correctly.
→ **“Load the media into the printer” P.43**
- Did you set up the origin?
Cancel or reset the settings of the origin.
→ **[Setup] P.115 > [Print preferences] P.117 > [Origin] P.118**
- Did you set an appropriate side margin?
Check the side margin setting.
→ **[Setup] P.115 > [Print preferences] P.117 > [Side Margin] P.118**

Ink does not dry easily after printing.

- Are you using a heater?
Check the heater settings.
→ **[Media Type] P.92 > [Heater] P.93**

Note

- If you are printing an image that uses a lot of ink, there is a risk that the ink may not dry easily after printing.
- Depending on media, ink may not dry easily

White or black line appears on the print.

- Check that the media is loaded into the printer correctly.
→ **“Load the media into the printer” P.43**
- Does the media contain moisture or are you using the creased or wrinkled media?
Replace with a new media.
- Are nozzles in good condition?
Run a nozzle check. If the nozzle is clogged, perform a head cleaning.
→ **“Nozzle check and head cleaning” P.56**
- Perform an “Adjust Print” calibration.
→ **“Adjust Print” P.94**
- Perform a “PF Adjust” calibration.
→ **“Media feed adjustment” P.100**
- Is the height of print head set appropriately for your media?
Check the height of print head.
→ **“Print head height” P.61**
- Are the parts around the print head clean?
→ **“Cleaning of the parts around the print head” P.141**

Printed lines are not aligned/ doubled, Print is faded/ bleeding

- Are nozzles in good condition?
Run a nozzle check. If the nozzle is clogged, perform a head cleaning.
→ **“Nozzle check and head cleaning” P.56**
- Perform an “Adjust Print” calibration.
→ **“Adjust Print” P.94**
- Perform a “PF Adjust” calibration.
→ **“Media feed adjustment” P.100**
- Is the ink bag within its expiration date?
Use ink bags that are within the expiration date.
- Are you printing on the print side of the media?
Check the print side of the media and load it correctly.

Printed color is not accurate

- Are nozzles in good condition?
Run a nozzle check. If the nozzle is clogged, perform a head cleaning.
→ **“Nozzle check and head cleaning” P.56**
- Did you install ink ink bags and smartchip cards in the printer in correct color combination?
If the combination is incorrect, perform the “Longstore” menu and then an initial ink charging.
→ **[Maintenance] P.107 > [Other Maintenance] P.107 > [Longstore] P.107**
- Have you set a count in "Multi Strike"?
Set it to 1 (cnt) again.
→ **[Setup] P.115 > [Print preferences] P.117 > [Multi Strike] P.118**

Nozzle clogging remains even after head cleaning

- Is it time to replace the following parts?
 - Cleaning wiper
 - Flushing box pad
 Check the condition of each part. Replace it if needed.
→ **“Replace the consumable parts” P.128**
- Are you using a correct cleaning wiper for the print head height?
→ **“Replace the cleaning wiper depending on the print head height” P.63**
- Did you select an appropriate cleaning mode?
→ **“Head cleaning mode” P.58**

Note

If nozzle clogging persists even after repeated Cleaning “Normal” attempts, try following troubleshooting steps:

1. Perform a cleaning "Long" two or three times. (If the problem persists, move to the next one)
→ **“Perform a head cleaning” P.58**
2. Clean the parts around the print head (parts around the print head and cleaning wiper). (If the problem persists, move to the next one)
→ **“Cleaning of the parts around the print head” P.141**
3. Perform a "Little Charge" two or three times. (If the problem persists, move to the next one)
→ **“Little Charge” P.144**
4. Perform a "Soak Cleaning".
→ **“Soak Cleaning” P.145**
5. If nozzle clogging persists even after “Soak Cleaning”, you can select the nozzles which fire properly.
→ **“Select Nozzle” P.148**

Media is jammed

- 1 Turn off the printer.
→ [“Turn off the printer” P.42](#)
- 2 Open the front cover.
- 3 Move the carriage off the media.

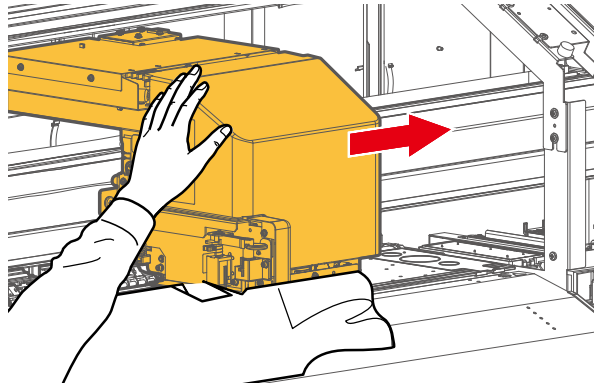

Important!

When the print head height is set to “Low1” or “Low2”, change it to “High” and then move the carriage. After moving, change the head height back to Low1 or Low2.

→ [“Print head height” P.61](#)

- 4 Remove the edge holder from the media.

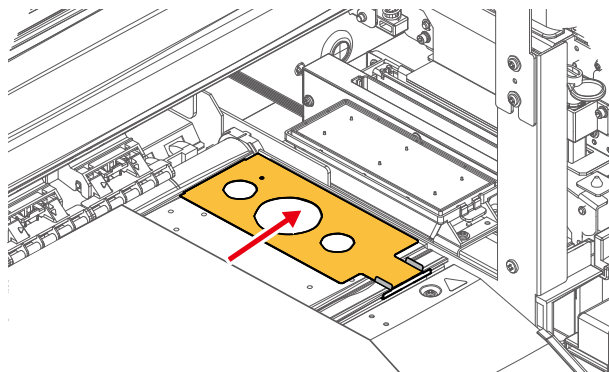

Important!

If the edge holder is deformed, stop using the printer and contact your local MUTOH dealer.

5 Raise the pressure rollers.

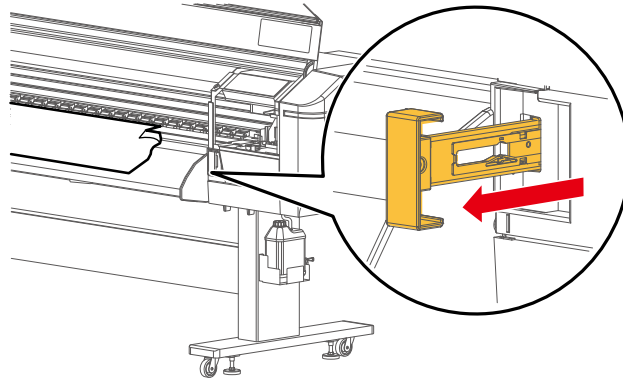

6 Pull the media toward the front and use a personal cutter to cut the torn part of the media along the groove.

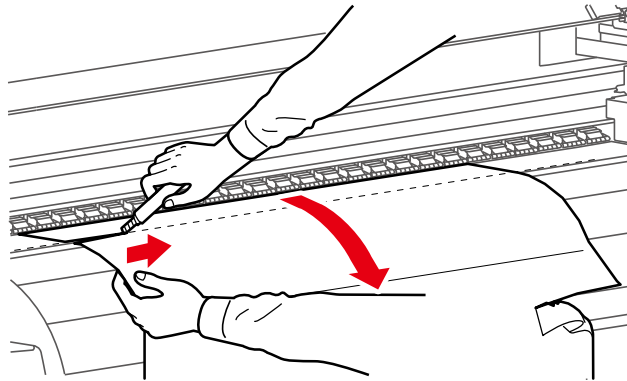

7 Rotate the flange of the roll media holder to rewind the media onto the roll.

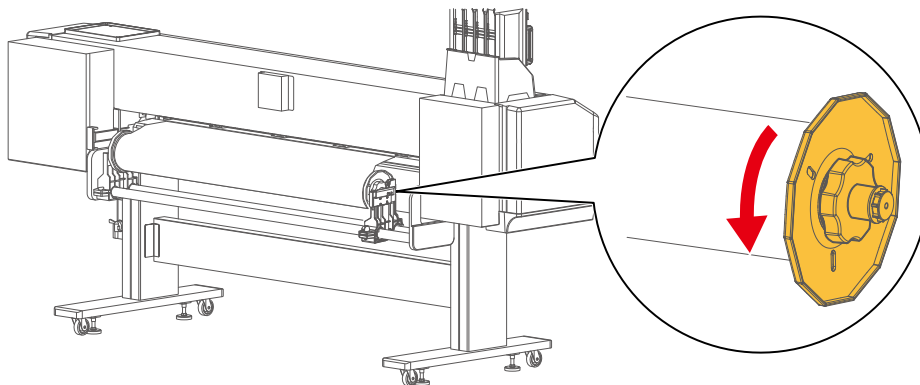

8 If paper dust or pieces of paper remain inside the printer, remove them.

9 Turn on the printer.

→ **“Turn on the printer” P.39**

10 Load a roll media to print a nozzle check pattern.

→ **“Load the media into the printer” P.43**

-
- 11** Tap [**<**] key while [**Print Ready**] is displayed on the panel.

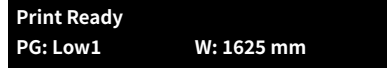

Print Ready
PG: Low1 W: 1625 mm

-
- 12** Tap [**Enter**] key.
The printer begins printing a nozzle check pattern F.



Nozzle check F
Start —> Enter

-
- 13** Check the pattern printed.
- If the nozzle is clogged, go to **“Perform a head cleaning” P.58**.
 - If all lines are clearly printed, you can start printing.
-

6 Appendix

Specifications	193
Optional accessories / Consumable supplies	196
Revision history	197

Specifications

Model name	XPJ-1641SR-P II	
Printing method	On-demand piezo method	
Driving method	Firmware servo / DC motor drive	
Media feeding method	Multipoint pressurized grid roller system	
Media hold-down system	Pressure rollers down system with manual lever	
Media size	Outer diameter	Up to 200 mm
	Paper core diameter	2 inch or 3 inch
	Weight	Up to 30 kg
	Width	500 mm to 1,625 mm
	Recommended media thickness	Up to 1.0 mm
Maximum printable width	1,615 mm	
Maximum printable length	1,500 m	
Head height adjustment	Four adjustment options: Low1 / Low2 / Middle / High	
Interface	Gb-Ethernet (1000BASE-T)	
Waste ink tank	Fixed tank with 2,000 ml capacity. Empty the tank when needed.	
Ink	Colors	4 colors (black, cyan, magenta, yellow)
	Type	1,000 ml ink bag (Cleaner is 300ml)

Environmental Requirements	Printer operation environment	Temperature: 20 °C to 32 °C Humidity: 40 % to 60 %, non-condensing	
	Recommended printing environment	Temperature: 22 °C to 30 °C Humidity: 40 % to 60 %, non-condensing	
	Change rate	Temperature: within 2 °C per hour Humidity: within 5 % per hour	
	Printer storage environment	<ul style="list-style-type: none"> Storage without ink filled: within 6 months Temperature: -20 °C to 60 °C Humidity: 20 % to 80 %, non-condensing Storage with ink filled: within 1 week Temperature: 5°C to 40°C When stored between 32 °C to 40 °C: within 4 days Humidity: 20 % to 80 %, non-condensing 	
	Ink storage environment	<ul style="list-style-type: none"> Black, Cyan, Magenta, Yellow (1,000 ml each) Temperature: -20 °C to 40 °C Humidity: 5 % to 85 %, non-condensing When stored at 40 °C: within 1 month Keep away from heat and flammable materials. Store in a cool, dark and well-ventilated place. Cleaning bag (300 ml) Temperature: -5 °C to 40 °C Humidity: up to 80 %, non-condensing When stored between -5 °C to 5 °C or 30 °C to 40 °C: within 6 months 	
Power supply specifications	Printer:	Input voltage	AC 100 V to 120 V ± 10% AC 200 V to 240 V ± 10%
		Input frequency	50 / 60 Hz ± 1 Hz
		Input current	AC 100 V to 120 V: 9.0 A or less AC 200 V to 240 V: 6.0 A or less
	Heater:	Input voltage	AC 100 V to 120 V ± 10% AC 200 V to 240 V ± 10%
		Input frequency	50 / 60 Hz ± 1 Hz
		Input current	AC 100 V to 120 V: 10.0 A or less AC 200 V to 240 V: 5.0 A or less
Power consumption	Power off	<ul style="list-style-type: none"> Printer AC 100 V to 120 V: 1.0 W or less AC 200 V to 240 V: 3.8 W or less Heater AC 100 V to 120 V: 0.1 W or less AC 200 V to 240 V: 0.2 W or less 	
	Ready-to-print	<p>(Without heater used)</p> <p>AC 100 V to 120 V: 45 W or less AC 200 V to 240 V: 45 W or less</p> <p>(With heater used)</p> <p>AC 100 V to 120 V: 1200 W or less AC 200 V to 240 V: 1200 W or less</p>	

	Sleep Mode	AC 100 V to 120 V: 30 W or less AC 200 V to 240 V: 30 W or less
	Operation	<ul style="list-style-type: none"> • Printer AC 100 V to 120 V: 1100 W or less AC 200 V to 240 V: 1100 W or less • Heater AC 100 V to 120 V: 1200 W or less AC 200 V to 240 V: 1200 W or less
External Dimensions	Height	1,428 mm With ink bag case (1,000 ml) installed: 1,611 mm
	Width	2,770 mm
	Depth	895 mm
Weight	Printer	141 kg
	Stand	32 kg

Optional accessories / Consumable supplies

For information about optional accessories and consumable supplies, please contact your local MUTOH dealer.

Revision history

Date	Version	Manual control number	Supported firmware
2025.09	00	XPJ1641SRP2E-A-00	V.1.00
2026.03	01	XPJ1641SRP2E-A-01	V.2.00 or later

MUTOH